



**Freudenberg Schwab**  
Vibration Control

## **Vibration Control Technology Industry**

Catalogue 2012





The information in this product catalogue is based on the experience gained in decades of research on the development and manufacture of components for vibration control in the Freudenberg group. It represents the current state of our knowledge.

The function of many products is, however, not provided solely by the component. Indeed, in the specific application this effect depends on other parameters such as operating temperature, media and dirt from the outside. This and other, unknown, factors in practical use can have significant effect on the products.

Against this background, general statements on the function of the products in this catalogue are not possible. Information in this catalogue represents recommended values that might not be correct in every application. We therefore recommend you to discuss your specific application with our advisory service. In cases with high or special loads, for example due to aggressive media, the products should be selected in collaboration with us; here trials on reliability are often indispensable. In context of product optimization we reserve the right to change, without prior notice, the product

range, production sites, products and their manufacturing process as well as the information in this catalogue. All the previous issues become invalid on publication of this issue of the catalog. Duplication in any form requires express approval from Freudenberg Schwab Vibration Control GmbH & Co. KG, 16727 Velten, Germany

© Freudenberg Schwab Vibration Control GmbH & Co. KG.  
All rights reserved.





**We create safety, durability and comfort.**



Dear Customers,

in 2012 Freudenberg founded a new business group named Freudenberg Schwab Vibration Control that joins the vibration control expertise of Schwab Schwingungstechnik AG in Adliswil (Switzerland), Freudenberg Schwab GmbH in Henningsdorf and Freudenberg Schwingungstechnik Industrie GmbH & Co. KG in Velten.

The goal for this strategic realignment is to forcefully continue a long standing success story on the vibration control market for industrial applications.

Vibration Control components of Freudenberg Schwab Vibration Control are used for agricultural and construction machinery, mechanical engineering, wind energy, drives and railway industry.

The following catalogue program offers well-engineered high quality solutions for various vibration control applications.

We are happy to answer all your questions around our product range.

Sincerely  
Freudenberg Schwab Vibration Control

# Table of Contents

## Pre-Selection Vibration Control ..... 6

### Hydraulic Damping Components

Hydro Bush.....	8
Hydro Mount DL.....	12
Hydro Mount VL.....	15

### Elastomer Dampers

Ultra Bush.....	19
Spherical Mount.....	30
Conical Mount.....	34
V Mount.....	48
MO Mount.....	53
Machine Mount.....	58
Flat Mount.....	60
Rails.....	62
Tapered Mount.....	64
Double U-Shear Mount.....	66
Circular Mount.....	69
Buffer.....	86
M Mount.....	91
Instrument Mount.....	94
O-Shaped Mount.....	96
Top Mount.....	99
Spherical Roller Bearing.....	102
Layered Springs.....	104

### Component Parts

Rubberised Stop Washer.....	106
Washers and Centering Washers.....	108

**Pre-Selection Vibration Control**

The table is based on years of supplier activity and is adapted to current knowledge.

	Hydro Bush	Hydro Mount DL	Hydro Mount VL	Ultra Bush	Spherical Mount	Conical Mount	V Mount	MO Mount	Machine Mount	Flat Mount	
Exhaust-air ducts, exhaust pipes, ...								•			
Electrical/electronic components and subassemblies				•		•					
Instruments, devices, displays, ...				•							
Levers, steering gear, coupling links, ...				•	•						
Cabs, superstructures, ...	•	•	•	•		•				•	
Radiators				•				•			
Bearings general	•	•	•	•	•	•	•	•	•	•	
Measuring devices	•	•	•				•				
Reaction-support links	•	•	•	•	•	•	•				
Pumps	•	•	•	•		•	•		•	•	
Mixers, separators, centrifuges, agitators, ...	•	•	•	•		•	•		•	•	
Stirrers	•	•	•	•	•	•		•		•	
Screen mounts				•							
Panels								•			
Rolling mills							•		•	•	
Maintenance-free articulation				•	•						
Machine tools	•	•	•	•		•	•	•	•	•	
Engines, units, compressors, ...	•	•	•	•		•	•	•	•	•	
Subassemblies, attached devices, ...	•	•	•	•	•	•	•	•	•	•	
Stationary machines and gearboxes, ...	•	•	•	•		•	•		•	•	
Levelling											
Limitation of movements											
Hydraulic and pneumatic hoses											

	Rails	Tapered Mount	Double U-Shear Mount	Circular Mount	Buffer	M Mount	Instrument Mount	O-Shaped Mount	Top Mount	Spherical Roller Bearing	Layered Springs	Washers and Centering Washers
			•	•				•				•
			•	•			•	•				•
			•	•			•	•				•
												•
		•										•
				•								•
	•	•	•	•	•	•	•	•	•		•	•
			•	•		•	•	•				•
				•	•				•			•
		•		•								•
		•		•	•	•						•
				•	•							
				•			•			•		•
	•			•			•				•	
	•			•								
	•	•	•	•	•	•	•	•	•		•	
	•	•		•					•			•
		•	•	•	•	•	•	•	•			•
	•	•		•		•					•	•
												•
												•



# Hydro Bush

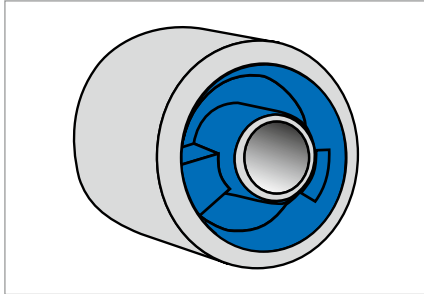

Fig. 1 Hydro Bush

## Material

Standard material	Hardness
Natural rubber	35, 45, 55, 62, 68 Shore A

## Operating conditions

Compressive forces in Z direction	1100 N ... 4200 N	Maximum permissible force
Max. temperature	+60 °C, transient +80 °C	
Min. temperature	-45 °C	

## Product description

Hydro bushes are elastomer springs with integrated hydraulic damping.

## Product advantages

- Frequency & amplitude selective damping
- Integrated limitation of the spring displacement
- Allowing twist in all directions
- Easily installed
- RoHS-compliant.

## Application

Suitable for mountings of combustion engines, cabs, pumps and compressors, mainly in agricultural machines and construction machinery.

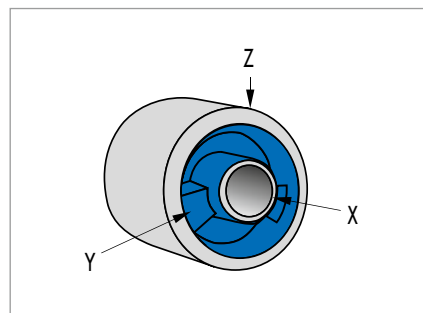

Fig. 2 Primary load directions

They are specifically suited when low frequencies occur as excitation frequency in the mount system. They achieve a high damping in the natural frequency range of the system as well as gut isolation properties above this range. Vibrations in the mount system which have a sound-conducting or radiating characteristic, generated primarily through excitation amplitudes or dynamic forces in the audible frequency

range are significantly reduced. The integrated hydraulic mechanism in the bush with the frequency and amplitude dependent damping is designed for effect in the Z direction. By matching the damping maximum of the hydro bush to the critical frequency (resonance frequency) of the spring-supported mass, the resonance magnification can be noticeably reduced. For higher frequencies, the insulating capability of elastomer bond components can be utilised. The hydro bushes are designed so that the translatory stiffness increase in the order X,Z,Y. The bushes are designed for the primary load in the radial (Z direction) as well as the axial direction (X direction) but can also absorb slight cardanic and torsional deformations. Depending on the design, limiters for deflection (labelled as HD) with or without reinforcement can be integrated in the Z direction.



## Design notes

The mount configuration comprises an elastomer-metal composite with load-bearing element in Vee-shape, stops, fluid chambers and overflow ducts. The composite is mounted in an outer sleeve and fluid-filled.

## Fitting & installation

- Hydro bushes have an outside fit and accommodate a threaded fastener on the inside for installation
- Hydro bushes can be secured with Loctite or other, similar adhesive if a press fit is not desired
- Individual components permit slight adjustment to allow for in-situ offset
- Always install hydro bushes centred and at right angles to the axis of primary radial load and if possible, utilise the entire cylindrical surface area of the outer sleeve as the bearing surface
- If possible, utilise the entire cylindrical length of the inner sleeve bore as the bearing surface
- Position the bush relative to the weight load in such a way as to reduce the largest distance between the axis of the inner sleeve to the axis of the outer sleeve in the place through both axes.

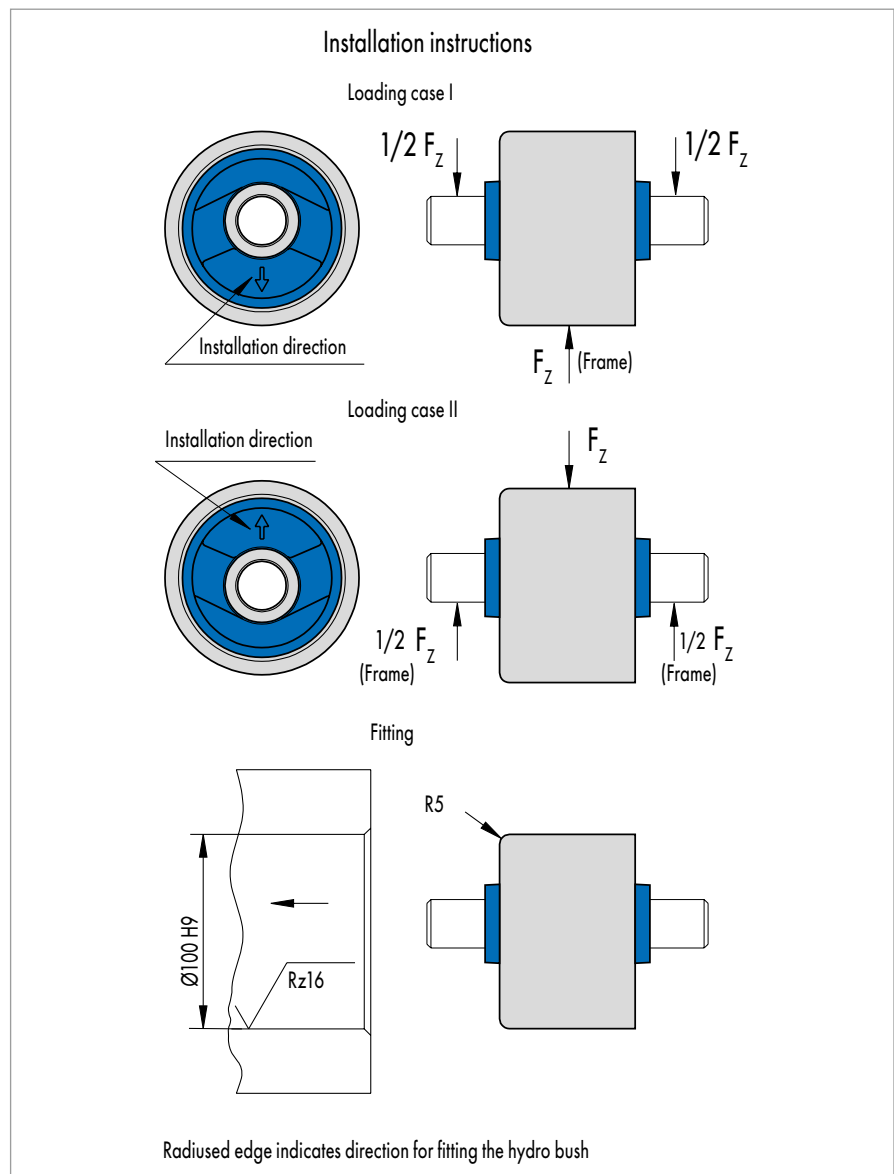

Fig. 3 Fitting & installation instructions: Hydro Bushes

Article list

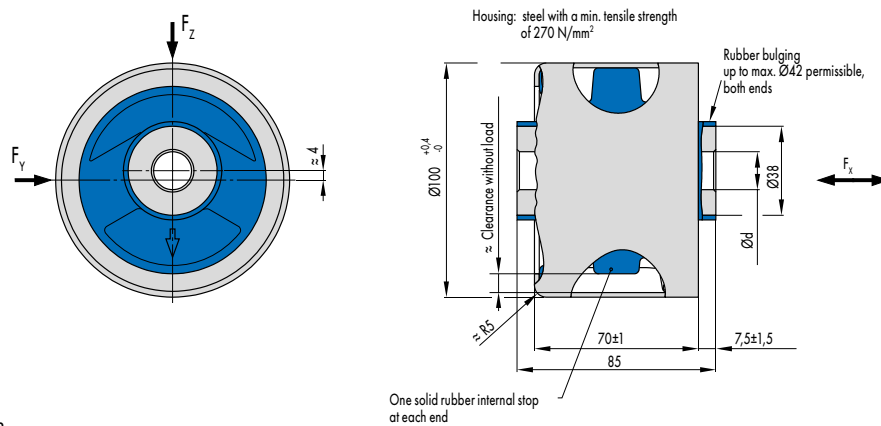

Fig. 4 Hydro Bush

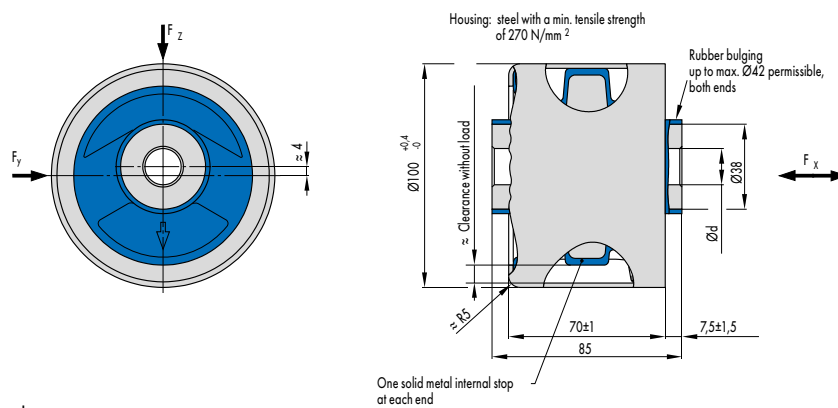

Fig. 5 HD-rated Hydro Bush

Nominal values of the maximum amounts		Stiffness					Inside Ø.		Product No.	Material	Type	Article No.		
		Radial		Axial		Radial	Radial	d						Tol.
		$F_z \text{ max}$	$s_z \text{ max}$	$c_x$		$c_y$								
[N]	[mm]	$s_z=0\text{mm}$	$s_z=5\text{mm}$	$s_z=0\text{mm}$	$s_z=5\text{mm}$	[N/mm]	[mm]							
1100	5	95	110	255	300	220	25	H9	046 18 013	35 NR 11	–	95573	•	
1100	5	95	110	255	300	220	32	H9	046 18 711	35 NR 11	–	49022801	○	
1100	5	95	110	255	300	220	32	H9	046 18 712	35 NR 11	HD	49022862	○	
1600	5	190	220	500	600	320	25	H9	046 18 014	45 NR 11	–	595574	•	
1600	5	190	220	500	600	320	32	H9	046 18 708	45 NR 11	–	507315	•	
1600	5	190	220	500	600	320	32	H9	046 18 713	45 NR 11	HD	49022863	○	
2500	5	280	330	750	830	500	25	H9	046 18 015	55 NR 11	–	595575	•	
2500	5	280	330	750	830	500	32	H9	046 18 714	55 NR 11	–	49022864	○	
2500	5	280	330	750	830	500	32	H9	046 18 705	55 NR 11	HD	477895	•	
3450	5	360	425	960	1070	685	32	H9	046 18 016	62 NR 11	–	595576	•	
3450	5	360	425	960	1070	685	32	H9	046 18 715	62 NR 11	HD	49022865	○	
4200	5	440	520	1170	1300	840	32	H9	046 18 017	68 NR 11	–	95676	•	
4200	5	440	520	1170	1300	840	32	H9	046 18 702	68 NR 11	HD	600984	•	

• Available from stock    ○ On request: Tool is available, delivery at short notice

**Static and dynamic characteristics**

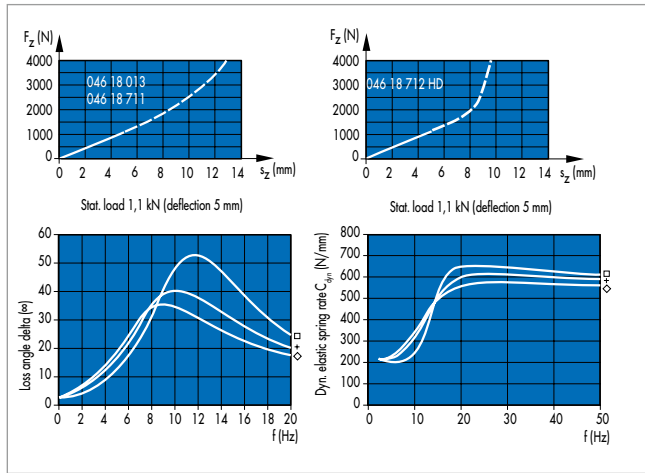

Fig. 6 Hydro Bushes 046 18 013, 046 18 711 and 046 18 712 HD

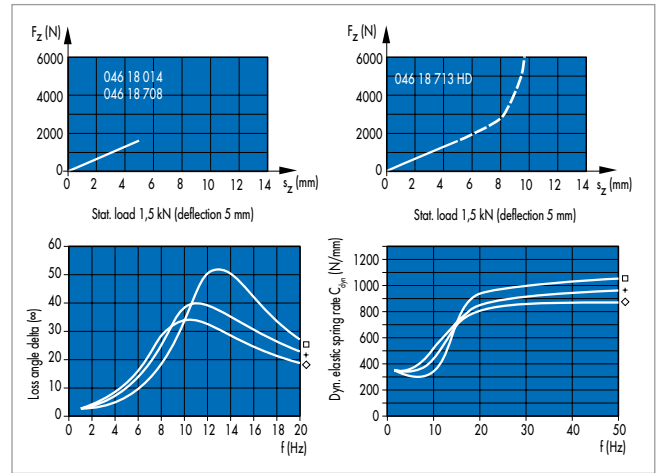

Fig. 7 Hydro Bushes 046 18 014, 046 18 708 and 046 18 713 HD

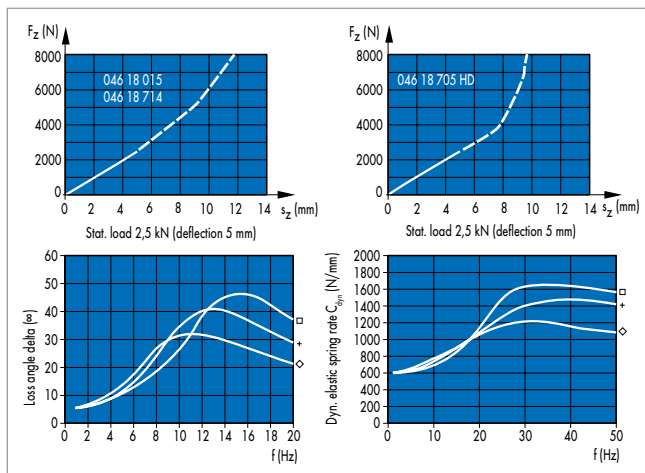

Fig. 8 Hydro Bushes 046 18 015, 046 18 714 and 046 18 705 HD

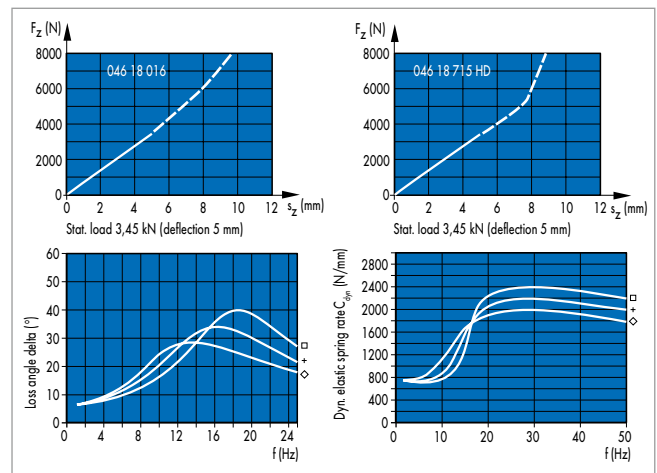

Fig. 9 Hydro Bushes 046 18 016 and 046 18 715 HD

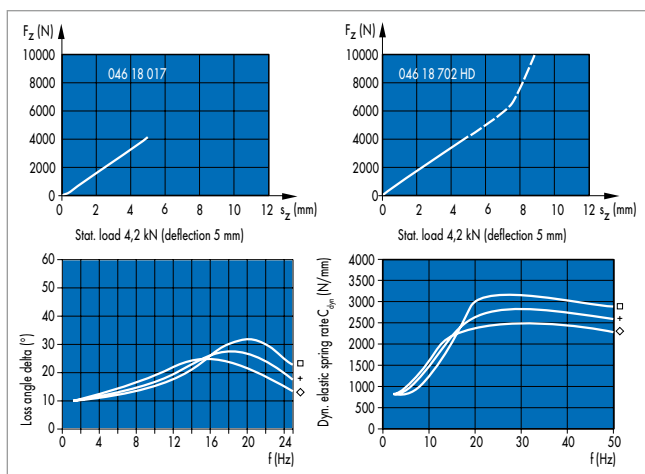

Fig. 10 Hydro Bushes 046 18 017 and 046 18 702 HD

Frequency  $f$  (Hz)      □ Amplitude  $\pm 1$  mm  
                                   + Amplitude  $\pm 2$  mm  
                                   ◇ Amplitude  $\pm 3$  mm

# Hydro Mount DL

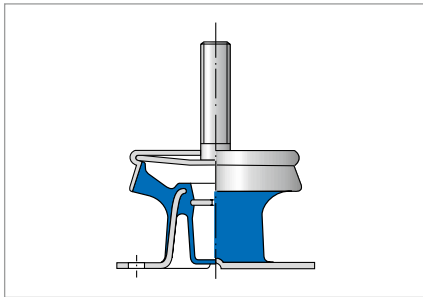

Fig. 1 Hydro Mount DL

## Material

Standard material	Hardness
Natural rubber	50, 55, 60, Shore A

## Operating conditions

Compressive forces in Z direction	700 N ... 1700 N	Maximum permissible force
Max. temperature	+60 °C, transient +80 °C	
Min. temperature	-45 °C	

## Product description

The hydro mount, as a hydraulically damping rubber mount, solved the designer's conflict of how to mount a mass that is excited by wide frequency spectrum. Particularly if low frequencies – between 5 Hz and 15 Hz – can occur as the excitation frequency, on the one hand high damping in the natural frequency range of the system, and on the other, a good isolation property above this natural frequency (supercritical mounting) is necessary.

## Product advantages

- Frequency & amplitude selective damping
- Cross-stiffness
- Integrated capability for levelling the load
- HD version for "extra-hard" use
- RoHS-compliant.

## Application

Hydro Mounts DL are suitable for use as mounts for pumps, compressors and engines in utility vehicles and in boats and for vehicle superstructures, particularly driver's cabs.

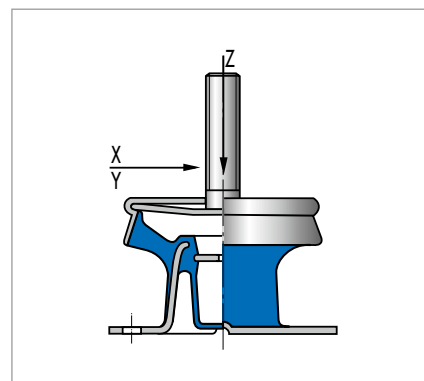

Fig. 2 Primary load directions

Hydro Mounts DL are predominantly used in vehicles of all types. In these applications the related assembly must be mounted as softly as possible to achieve a good structure-borne sound isolation. At low frequencies near the natural frequency of the spring-mass system engine/engine mounts, such soft mounting results in inadmissibly high amplitudes at the motor. Hydro Mounts DL have a soft spring characteristic and thus a large static deflection.

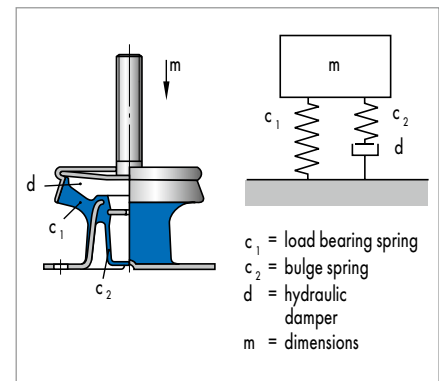

Fig. 3 Mode of operation

The hydraulic mechanism with frequency and amplitude dependent damping integrated in the mount is designed for effect in the Z direction. By matching the damping maximum of the mount to the critical frequency (resonance frequency) of the spring-supported mass, the resonance magnification can be noticeably reduced. For higher frequencies, the insulating capability of elastomer bond components can be utilised. These hydro mounts have a greater flexibility in the Z direction than in the X,Y direction. Hydro mounts are designed for primary loading in the axial as well as radial direction but they can also withstand car-danic deformation. The longitudinal axis should be selected for the introduction of the static primary load.

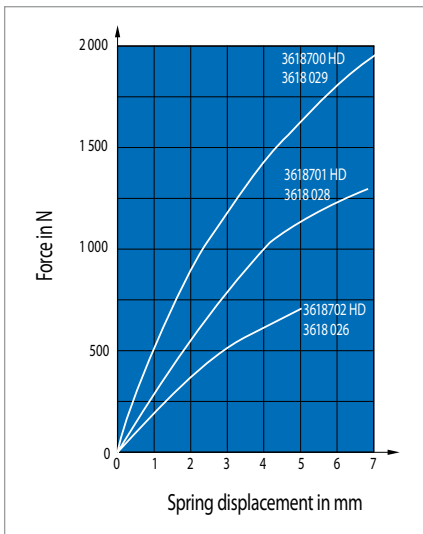

Fig. 4 Static spring characteristic curve in Z direction

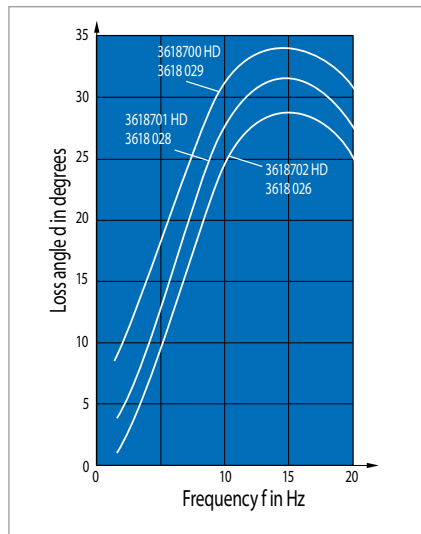

Fig. 5 Transient of the loss angle as a function of frequency

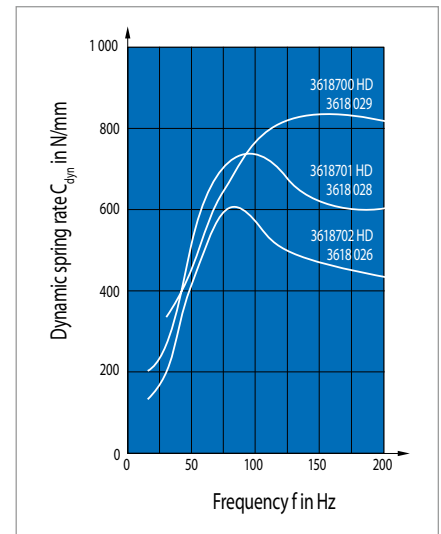

Fig. 6 Dynamic spring rate as a function of frequency

### Design notes

The mount configuration comprises a conical mount with integrally moulded/integral expansion bellows with threaded stud. The expansion bellows is filled with a special fluid. A control plate is located between the expansion bellows and the securing plate for setting of the specific hydraulic damping characteristics.

### Fitting & installation

- Hydro mounts are designed to be secured by means of the threaded fastener with securing plate assembly and the flange of the conical mount
- Individual components permit slight adjustment to allow for in-situ offset or angular offset
- It is important to ensure that the mating faces of the frame and the mass carried by the mount are flat and smooth
- In particular, the area underneath the flange mount must be free of sharp edges, burrs and filings, so that the rubber element can expand on it without risk of damage
- Position the mount relative to the static load in such a way that securing plate and flange are preloaded relative to each other
- Use HD-rated hydro mounts by preference for applications with extra-harsh conditions characterised by many hard shock loads: fork-lift trucks running on solid-rubber tyres is a typical example.

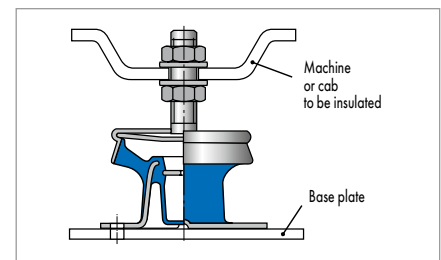

Fig. 7 Fitting & installation instructions: Hydro Mount DL

Article list

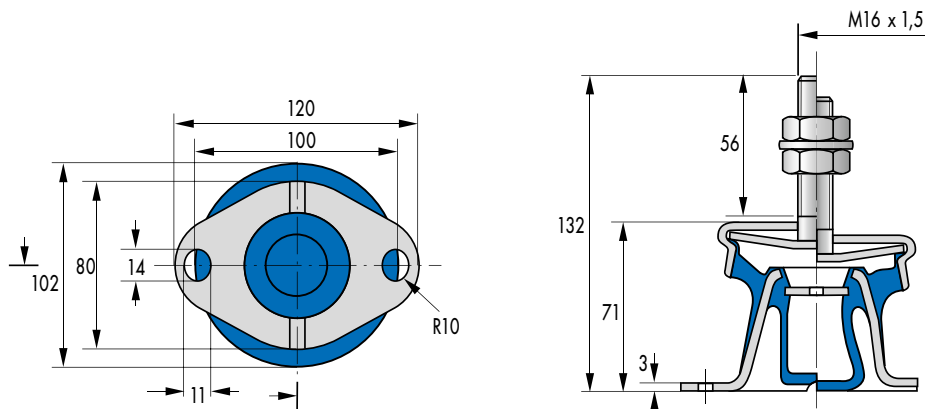

Fig. 8 Hydro Mounts DL 036 18 026, 036 18 028, 036 18 029, 036 18 700, 036 18 701, 036 18 702

Nominal values of the maximum amounts		Stiffness			Product No.	Material	Type	Article No.	
Axial pressure		Radial shear		Axial pressure					
$F_z$ max	$s_z$ max	$c_x$	$c_y$	$c_z$					
		$s_z=5\text{mm}$	$s_z=5\text{mm}$	$s_z=2,5\text{mm}$					
[N]	[mm]	[N/mm]	[N/mm]	[N/mm]					
700	5,0	143	143	142	036 18 026	50 NR 11	-	93638	•
1200	5,6	200	200	243	036 18 028	55 NR 11	-	93639	•
1700	5,4	230	230	350	036 18 029	60 NR 11	-	93640	•
700	5,0	143	143	142	036 18 702	50 NR 11	HD	49022858	•
1200	5,6	200	200	243	036 18 701	55 NR 11	HD	2129442	•
1700	5,4	230	230	350	036 18 700	60 NR 11	HD	511065	•

• Available from stock    ○ On request: Tool is available, delivery at short notice

## Hydro Mount VL

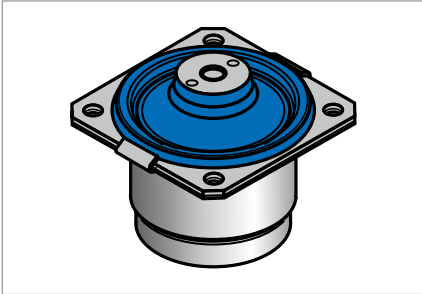

Fig. 1 Hydro Mount VL

### Product description

The mount design, the chosen fluid and the hydraulic mechanism provide the characteristic wide-band damping. In cases with remote excitation frequencies in the lower frequency range, the use of this hydro mount permits an optimal mounting. By precise reduction of the fluid chamber stiffness of one of the chambers, a significantly improved compromise of effective vibration reduction and structure-borne sound isolation is achieved as opposed to the hydro mounts without this design.

### Product advantages

- Broad-band damping at high amplitudes
- Significantly reduced damping at low amplitudes
- Optimised elastomer spring
- Compact
- RoHS-compliant.

### Application

The Hydro Mount VL offers a wide range of possible applications such as cab and engine mounts, for agricultural and construction machinery, industrial vehicles, forest machinery, communal vehicles, ships and for mounting superstructures, pumps and compressors. It is equally suited for mounting machinery and systems/units with severe resonance transients.



**Material**

Standard material	Hardness	Special design
Natural rubber	40, 45, 50, 55, 60, 65 Shore A	on enquiry

**Operating conditions**

<b>Axial forces in Z direction</b>	3000 N ... 8500 N	Maximum permissible force
<b>Max. temperature</b>	+60 °C, transient +80 °C	
<b>Min. temperature</b>	-45 °C	

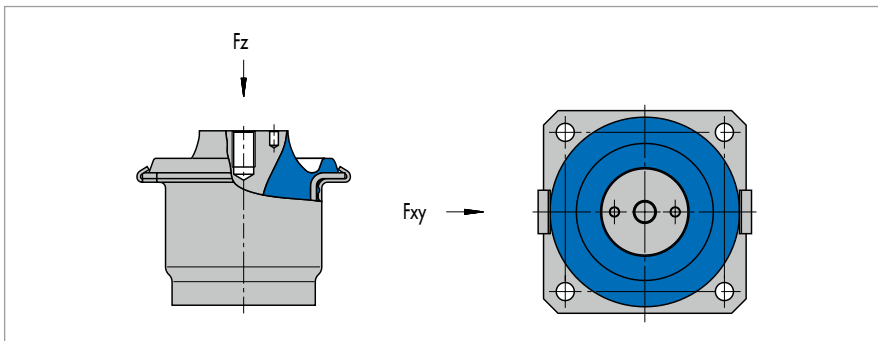

Fig. 2 Primary load directions

The hydraulic mechanism with frequency and amplitude dependent damping integrated in the mount is designed for effect in the Z direction. The effective damping over the wide-band frequency is also present for changes to the spring-supported mass. At low excitation amplitudes, the Hydro Mount VL has a significantly reduced damping. Hydro

Mounts VL have a greater flexibility in the Z direction as in the X,Y direction. The mount configuration is designed for primary loading in the axial as well as radial direction but it can also withstand cardanic deformation. The longitudinal axis should be selected for the introduction of the static primary load.

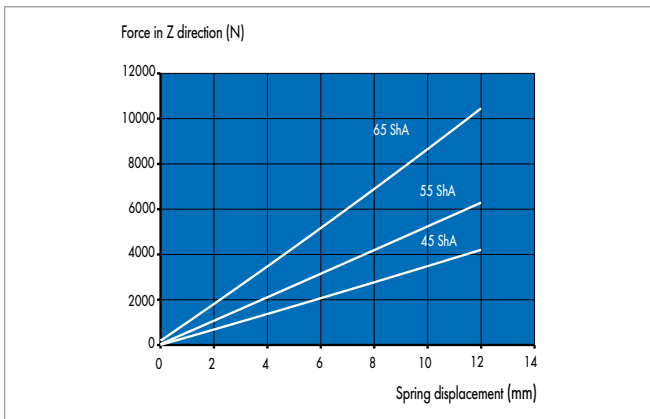

Fig. 3 Force-deflection characteristics, 036 18 704

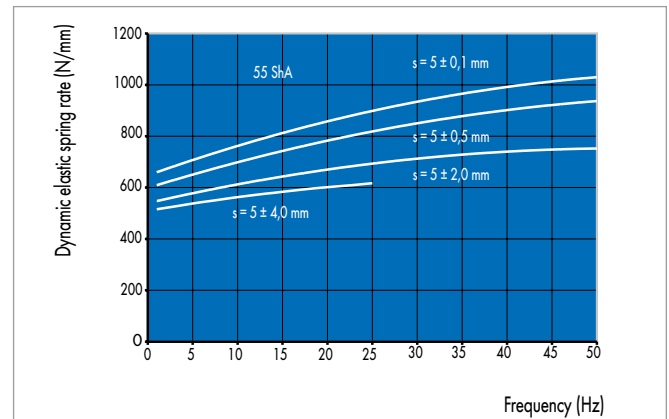

Fig. 4 Dynamic spring rate, 036 18 704; 55 ShA

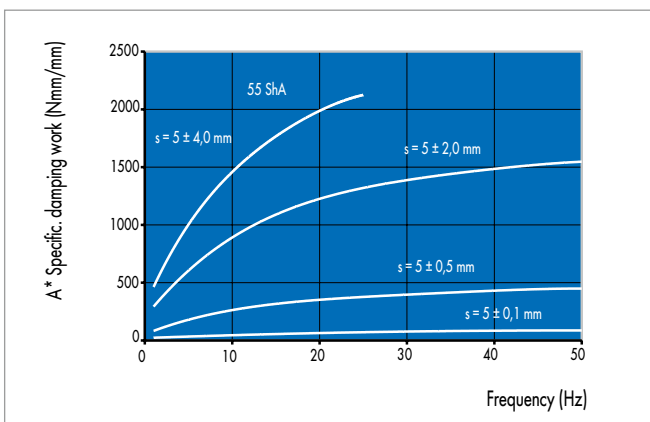

Fig. 5 Specific damping work, 036 18 704; 55 ShA

### Design notes

The mount configuration comprises a conical mount with outer metal component with rectangular flange and bore holes. It also contains an inner metal component with central thread hole to which a washer is attached which extends into a fluid-filled chamber. This is formed by the tapered mount and the cup mounted on the tapered mount. The base of the cup is closed off with a diaphragm.

### Fitting & installation

- Hydro Mounts VL are designed to be secured by means of threaded fasteners
- Individual components permit slight adjustment to allow for in-situ offset
- The flat part of the flange must make full-surface contact with the supporting structure
- It is important to ensure that the mating face is flat and smooth, and the same applies to the mating face of the mass carried by the mount. It is also important to ensure full-surface contact with the inner metal part of the mount
- Position the mount relative to the static load in such a way that the inner metal part of the conical mount and the flange are preloaded relative to each other.

Article list

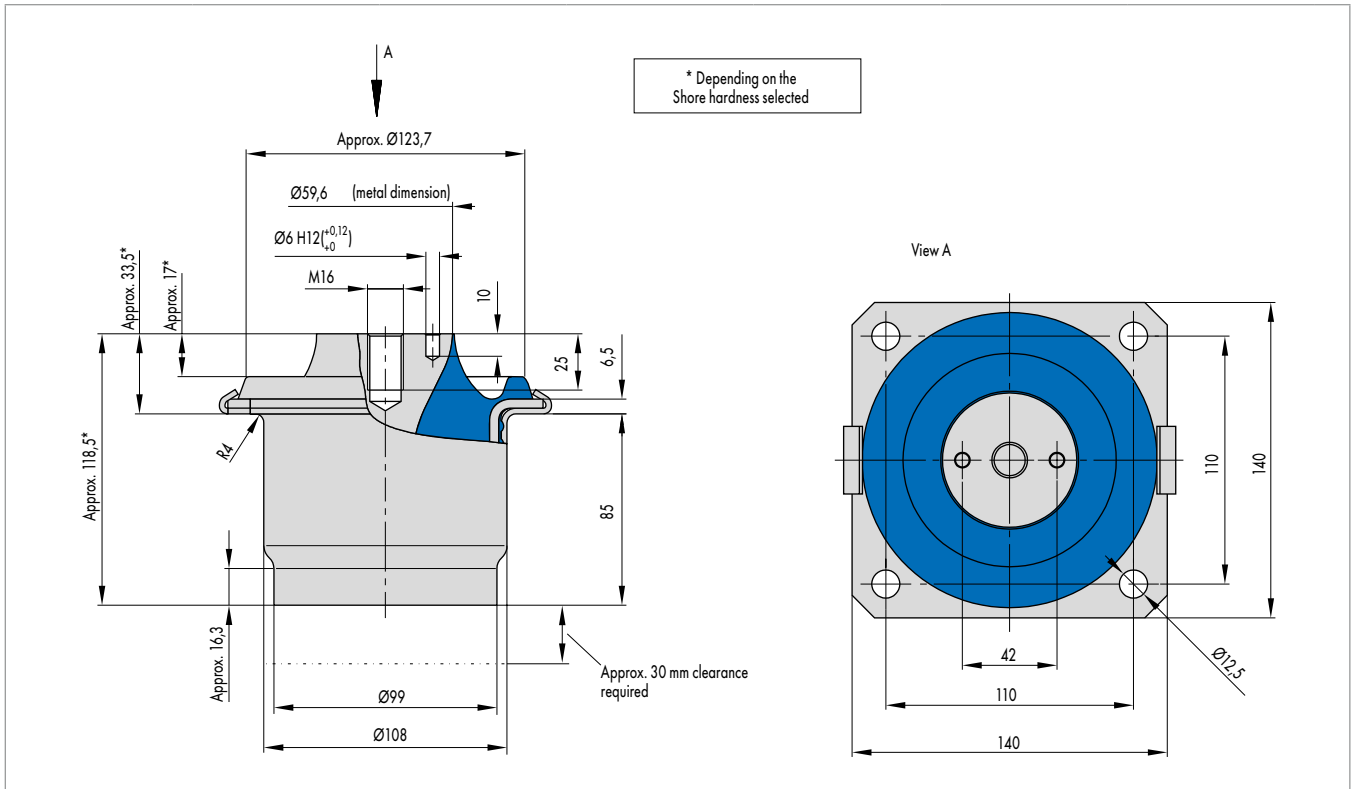

Fig. 6 Hydro Mount VL 036 18 704

Nominal values of the maximum amounts		Stiffness		Product No.	Material	Article No.	
Axial pressure		Radial shear	Axial pressure				
$F_z$ max	$s_z$ max	$c_{x, y}$	$c_z$				
[N]	[mm]	( $s_z = 0$ )	( $s_z = 5$ )				
[N]	[mm]	[N/mm]	[N/mm]				
2600	10	380	260	036 18 704	40 NR 11	49028132	•
3100	10	440	310	036 18 704	45 NR 11	49023248	•
3900	10	580	380	036 18 704	50 NR 11	49028133	•
4700	10	760	470	036 18 704	55 NR 11	49023250	•
6200	10	1050	600	036 18 704	60 NR 11	49028134	•
8000	10	1360	740	036 18 704	65 NR 11	49023251	•
3000	10	500	300	036 18 706	40 NR 11	49039034	○
3900	10	650	390	036 18 706	45 NR 11	49039035	○
4600	10	800	460	036 18 706	50 NR 11	49039036	○
5500	10	1100	550	036 18 706	55 NR 11	49039037	○
7000	10	1500	700	036 18 706	60 NR 11	49039038	○
8800	10	1950	880	036 18 706	65 NR 11	49039039	○
2100	10	270	210	036 18 707	40 NR 11	49039040	○
2700	10	350	270	036 18 707	45 NR 11	49039041	○
3000	10	450	300	036 18 707	50 NR 11	49039082	○
3600	10	600	360	036 18 707	55 NR 11	49039083	○
4800	10	830	480	036 18 707	60 NR 11	49039084	○
5700	10	1100	570	036 18 707	65 NR 11	49039085	○

• Available from stock    ○ On request: Tool is available, delivery at short notice

## Ultra Bush

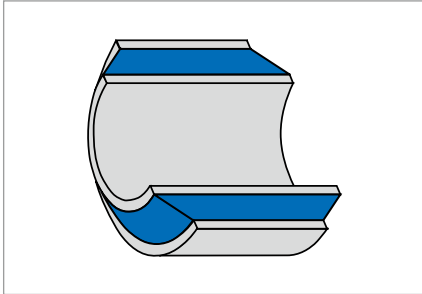

Fig. 1 Ultra Bush

### Product description

The ultra bush is a cylindrical bush capable of absorbing axial, radial and torsional movements and cardanic deflections.

### Product advantages

- Maintenance-free
- Prevents sound transmission
- Adjustment of manufacturing tolerances
- Usable as a coupling element in drives/powertrains

- Reduced settling under radial load
- Increases load-bearing capability in the radial direction
- RoHS-compliant.

### Application

Ultra bushes have a wide range of possible applications as resilient connecting element. Typical applications are elastic articulations on vibrating machines or bearing blocks for shafts, axles as well as steering gears and couplings.

### Material

Standard material	Hardness
Ethylene-acrylate rubber AEM 23, AEM 33	60 Shore A
Natural rubber NR 11, NR 91, NR 39, NR 97	40, 45, 60, 70 Shore A
Acrylonitrile-butadiene rubber NBR 68	60 Shore A

**Operating conditions**

Radial forces	350 N ... 460000 N	Maximum permissible force
Axial forces	120 N ... 60000 N	Maximum permissible force
Max. temperature	60 °C, transient +80 °C	
Min. temperature	-45 °C	

Ultra bushes are available in different versions by the specified article (see article list) which range for applications up to load ranges of 460 kN. Ultra bushes can tolerate radial axial, torsional and also slight cardanic deformation. The recommended primary loading direction is perpendicular to the longitudinal axis and centred to the longitudinal elongation (radial load).

When calculating dynamic loading, use values of  $s_a$  and  $s_r$  reduced by approx. 50%.

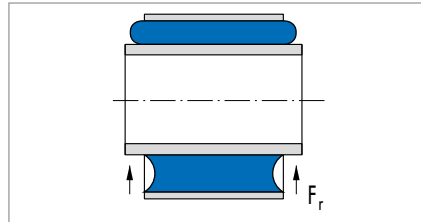

Fig. 2 Radial load

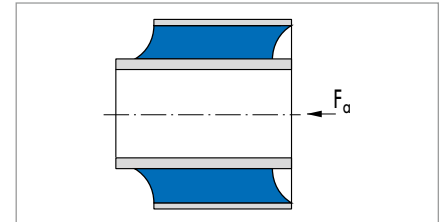

Fig. 3 Axial load

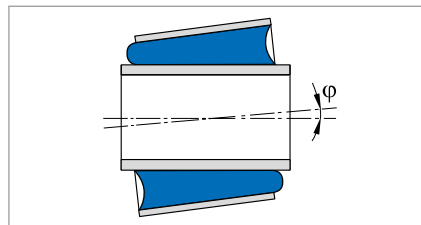

Fig. 4 Cardanic deflection

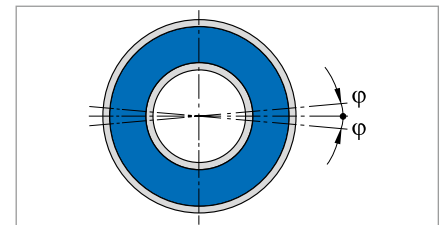

Fig. 5 Torsional load

**Design notes**

They are manufactured from an inside and outside precision metal sleeve which are joined together by a vulcanised elastomer insert. Ultra bushes have a pressure "preloaded elastomer" that is produced by permanently reducing the outside diameter of the outer sleeve and increasing the inside diameter of the inner sleeve through plastic deformation of the metal parts. This increases the service life considerably.

### Fitting & installation

- Ultra bushes are designed for inner and outer press fitting
- Individual components permit slight adjustment to allow for in-situ planar or angular offset
- If possible, ensure that the entire cylindrical surface area of the sleeves is utilised as load-bearing contact surface
- Always apply installation and removal press-fit forces uniformly to the end faces of the precision sleeves.

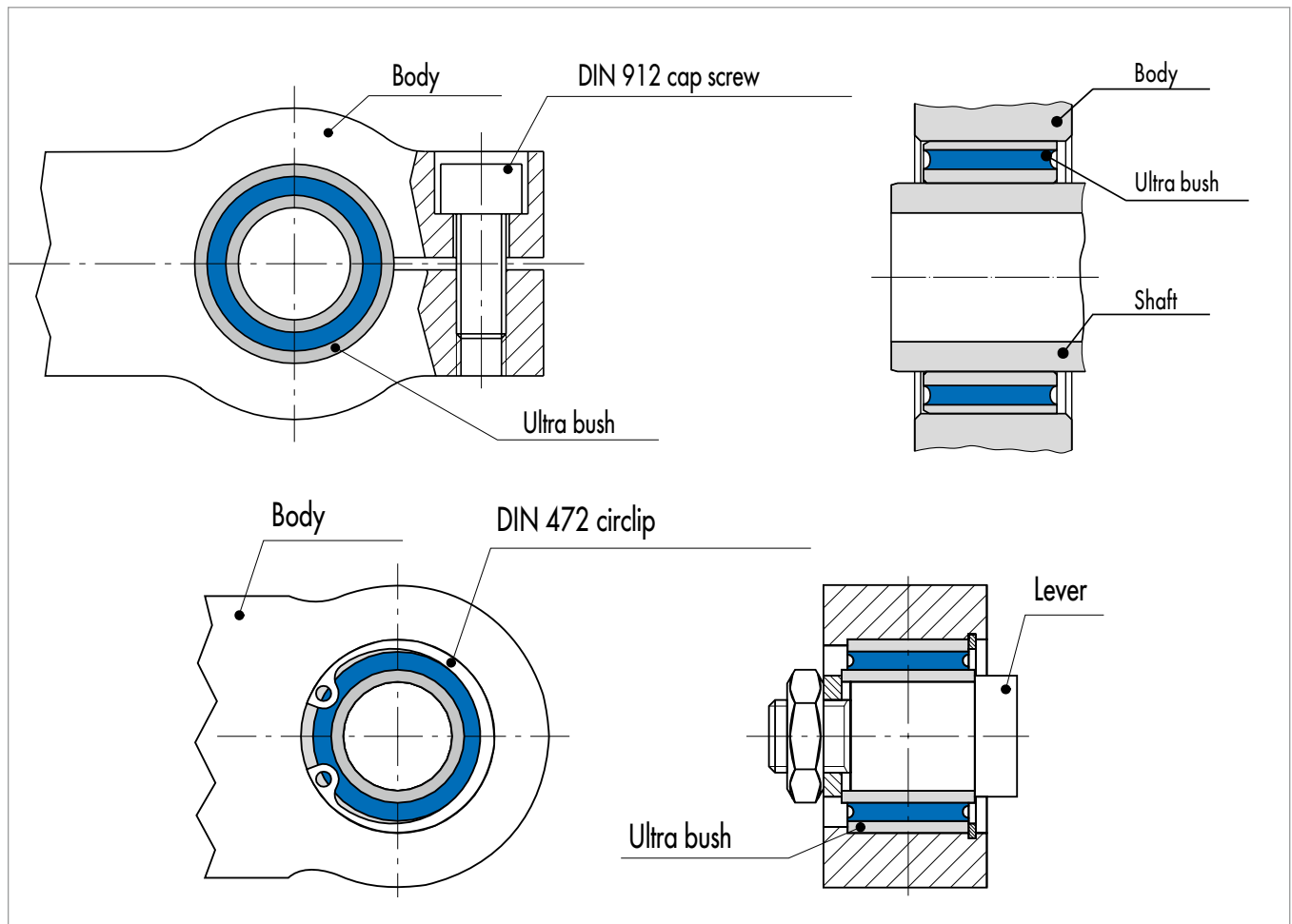

Fig. 6 Fitting & installation instructions: Ultra Bushes

Article list Ultra Bush

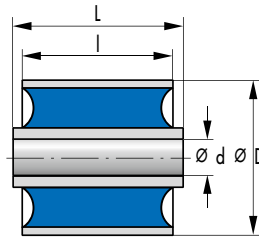

Fig. 7 Ultra Bush

Nominal maxima		Stiffness	Nominal maxima		Stiffness	Nominal maxima		Stiffness	Inside $\emptyset$	
Radial			Torsion			Axial			d	Tol.
$F_{r \max}$	$S_{r \max}$	$c_{rad}$	$M_{t \max}$	$\varphi_{\max}$	$C_{tor \Phi}$	$F_{a \max}$	$S_{a \max}$	$c_{ax}$		
[N]	[mm]	[N/mm]	[Nm]	[°]	[N/mm]	[N]	[mm]	[N/mm]	[mm]	
2700	0,4	6750	3,2	7,0	0,5	700	1,4	510	8	H9
450	0,4	1130	1,1	7,0	0,2	230	1,6	140	8	H9
2800	0,2	14000	2,0	3,5	0,6	410	0,6	680	10	H9
1200	0,3	4000	2,0	3,5	0,6	280	1,0	280	10	H9
1100	0,3	3670	2,7	12,6	0,2	120	0,6	200	10	H9
2100	0,3	7000	2,7	5,2	0,5	280	0,6	470	10	H9
1800	0,3	7200	3,0	5,0	0,6	525	1,0	530	10	H9
700	0,5	1400	1,2	6,6	0,2	210	1,6	130	10	H9
1900	0,5	3800	2,9	6,6	0,4	550	1,6	340	10	H9
1300	0,2	6500	4,0	4,3	0,9	600	0,7	860	12	H9
4700	0,3	15670	6,0	5,6	1,1	950	1,2	790	12	H9
3700	0,5	8220	4,7	5,4	0,9	650	1,2	540	12	H9
2700	0,6	4500	4,2	6,0	0,7	480	1,2	400	12	H9
2700	0,6	4500	4,2	6,0	0,7	480	1,2	400	12	H9
2700	0,6	4500	4,2	6,0	0,7	480	1,2	400	12	H9
350	0,6	580	1,3	7,4	0,2	130	1,5	90	12	H9
900	0,6	1500	3,0	7,4	0,4	300	1,5	200	12	H9
950	0,6	1580	2,1	7,2	0,3	230	1,4	160	12	H9
1650	0,6	2750	4,5	7,2	0,6	480	1,4	300	12	H9
1000	0,6	1670	2,9	7,5	0,4	320	1,5	210	12	H9
2400	0,6	4000	7,0	7,5	0,9	780	1,5	520	12	H9
7600	0,9	8440	11,0	7,7	1,4	1800	2,4	750	12	H9
2400	0,6	4000	7,0	6,7	1,0	1060	2,0	530	14	H9
630	0,6	1050	2,9	7,5	0,4	240	1,5	160	14	H9
1600	0,6	2670	6,0	7,5	0,8	640	1,5	430	14	H9
900	1,2	750	7,0	8,6	0,8	1200	3,6	330	14	H9
5500	0,4	13410	10,0	5,2	1,9	1200	1,4	880	16	H9
1100	0,6	1830	5,0	5,6	0,9	600	1,6	380	16	H9
2400	0,9	2670	10,0	8,1	1,2	1000	2,5	400	16	H9
4000	0,4	10000	7,3	4,4	1,7	650	1,2	540	18	H9
1700	1,2	1420	3,8	5,3	0,7	350	1,6	220	18	H9
2600	0,6	4330	9,2	5,3	1,7	1000	1,6	640	18	H9
5050	0,4	12630	13,0	5,3	2,5	1260	1,2	1050	18	H9
8200	0,5	16400	19,0	5,3	3,6	1700	1,8	940	20	H9
6300	0,6	10000	16,6	6,0	2,8	1600	2,2	730	20	H9

● Available from stock    ○ On request: Tool is available, delivery at short notice



	Outside Ø		Length of the outer bush		Length of the inner bush		Product No.	Material		Article No.	
	D	Tol.	l	Tol.	L	Tol.		Rubber	Metal		
	[mm]		[mm]		[mm]						
20	±0,10	35	±0,5	40	±0,3	001 18 168	60 NR 11	steel	90122	•	
22	±0,10	12	±0,5	20	±0,3	001 18 305	60 NR 11	steel	91237	•	
20	±0,10	20	±0,5	24	±0,3	001 18 036	60 NR 11	steel	90007	•	
22	±0,10	15	±0,5	16	±0,3	001 18 337	60 NR 11	steel	91497	•	
22	±0,10	18,5	±0,5	20,5	±0,3	001 18 156	40 NR 11	steel	91089	•	
22	±0,10	18,5	±0,5	20,5	±0,3	001 18 156	60 NR 11	steel	90112	•	
22	±0,10	20	±0,5	24	±0,3	001 18 037	60 NR 11	steel	90009	•	
25	±0,10	20	±0,5	24	±0,3	001 18 039	40 NR 11	steel	90012	•	
25	±0,10	20	±0,5	24	±0,3	001 18 039	60 NR 11	steel	90011	•	
22	±0,10	24	±0,5	28	±0,3	001 18 040	60 NR 11	steel	90014	•	
24	±0,10	36	±0,5	37	±0,3	001 18 287	60 NR 11	steel	92683	•	
25	±0,10	24	±0,5	28	±0,3	001 18 041	60 NR 11	steel	90016	•	
28	±0,10	24	±0,5	28	±0,3	001 18 043	60 NR 11	steel	90018	•	
28	±0,10	24	±0,5	28	±0,3	001 18 043	60 AEM 23	steel	90076	•	
28	±0,10	24	±0,5	28	±0,5	002 18 886	60 NR 11	Niro	49004146	•	
30	±0,10	17	±0,5	18	±0,3	001 18 157	40 NR 11	steel	90890	•	
30	±0,10	17	±0,5	18	±0,3	001 18 157	60 NR 11	steel	90113	•	
30	±0,10	24	±0,5	28	±0,5	001 18 044	40 NR 11	steel	49035877	•	
30	±0,10	24	±0,5	28	±0,5	001 18 044	60 NR 11	steel	90019	•	
30	±0,10	36	±0,5	40	±0,3	001 18 169	40 NR 11	steel	49035876	○	
30	±0,10	36	±0,5	40	±0,3	001 18 169	60 NR 11	steel	90123	•	
32	±0,10	55	±0,5	59	±0,3	001 18 158	60 NR 11	steel	90115	•	
32	±0,10	28	±0,5	32	±0,3	001 18 047	60 NR 11	steel	90021	•	
35	±0,10	28	±0,5	32	±0,3	001 18 048	40 NR 11	steel	90022	•	
35	±0,10	28	±0,5	32	±0,3	001 18 048	60 NR 11	steel	90023	•	
40	±0,10	28	±0,5	34	±0,3	001 18 049	60 NR 11	steel	90026	•	
30	±0,10	32	±0,5	38	±0,3	001 18 050	60 NR 11	steel	90028	•	
32	±0,10	16	±0,5	17	±0,3	001 18 159	60 NR 11	steel	90117	•	
40	±0,10	32	±0,5	38	±0,3	001 18 054	60 NR 11	steel	90032	•	
32	±0,10	20	±0,5	20	±0,3	001 18 170	60 NR 11	steel	90124	•	
34	±0,10	25	±0,5	25	±0,3	001 18 171	40 NR 11	steel	93000	•	
34	±0,10	25	±0,5	25	±0,3	001 18 171	60 NR 11	steel	91567	•	
34	±0,10	36	±0,5	42	±0,3	001 18 055	60 NR 11	steel	90033	•	
38	±0,10	40	±0,5	46	±0,3	001 18 060	60 NR 11	steel	90035	•	
40	±0,10	36	±0,5	36	±0,3	001 18 288	60 NR 11	steel	91270	•	

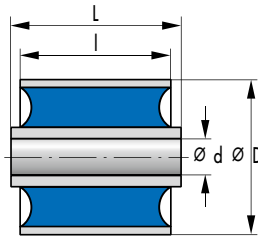

Nominal maxima		Stiffness	Nominal maxima		Stiffness	Nominal maxima		Stiffness	Inside Ø	
Radial			Torsion			Axial			d	Tol.
$F_{r \max}$	$S_{r \max}$	$c_{rad}$	$M_{t \max}$	$\varphi_{\max}$	$C_{tor \varphi}$	$F_{a \max}$	$S_{a \max}$	$c_{ax}$		
[N]	[mm]	[N/mm]	[Nm]	[°]	[N/mm]	[N]	[mm]	[N/mm]	[mm]	
7900	0,6	12540	19,0	5,9	3,2	1800	2,2	820	20	H9
1600	0,8	2000	7,5	7,0	1,1	830	3,0	280	20	H9
1600	0,8	2000	7,5	7,0	1,1	830	3,0	280	20	-0,15
4000	0,8	5000	18,0	7,0	2,6	2100	3,0	710	20	H9
4000	0,8	5000	18,0	7,0	2,6	2100	3,0	710	20	-0,15
1500	0,9	1670	5,8	7,1	0,8	450	2,0	230	20	H9
3700	0,9	4110	14,0	7,1	2,0	1100	2,0	550	20	H9
5400	1,0	5400	19,0	7,4	2,6	1750	2,7	650	20	H9
17500	1,2	14580	30,0	7,2	4,2	3600	3,2	1130	20	H9
5400	1,6	3420	19,0	8,1	2,3	2250	4,2	540	20	H9
18200	1,2	15170	70,0	15,9	4,4	3000	3,2	940	24	H9
37500	1,2	31250	70,0	6,6	10,6	5200	2,4	2170	24	H9
11000	0,4	27500	22,0	4,0	5,5	1350	1,1	1230	25	H9
11000	0,4	27500	22,0	4,0	5,5	1350	1,1	1230	25	H9
20000	0,4	57140	34,0	3,5	9,7	2000	0,9	2200	25	H9
20000	0,4	57140	34,0	3,5	9,7	2000	0,9	2200	25	H9
2500	0,5	5000	15,0	4,3	3,5	1200	1,6	750	25	H9
11500	0,6	18250	34,0	5,3	6,4	2800	1,8	1560	25	H9
10000	1,0	10000	34,0	6,6	5,2	2900	3,0	970	25	H9
4000	1,0	4000	17,0	6,8	2,5	1000	2,6	380	25	-0,15
8000	1,0	8000	35,0	6,8	5,1	2600	2,6	1000	25	-0,15
10000	1,0	10000	40,0	7,0	5,7	1600	2,0	800	28	H9
8800	0,6	14670	25,0	4,8	5,2	1200	1,6	750	30	H9
22000	0,6	36670	55,0	4,8	11,5	3100	1,6	1940	30	H9
13000	1,1	11820	63,0	7,0	9,0	3400	2,6	1310	30	H9
6700	1,3	5150	23,0	6,4	3,6	1500	3,9	380	30	H9
13700	1,3	10540	55,0	6,4	8,6	4000	3,9	1030	30	H9
15900	1,3	12230	55,0	6,4	8,6	3800	3,9	970	30	H9
13700	1,3	10540	55,0	6,4	8,6	4000	3,9	1030	30	H9
20200	0,4	50500	78,0	4,1	19,0	5400	2,0	2700	32	H9
20200	1,1	19240	96,0	5,8	17,0	6500	3,6	1810	36	H9
18500	0,8	231300	53,0	4,8	11,0	2100	2,8	750	38	H9
45000	0,8	56250	130,0	4,8	27,1	7400	2,8	2640	38	H9
20650	0,6	34420	130,0	4,7	27,7	6250	2,8	2260	40	H9
28000	1,5	18670	130,0	6,7	20,0	4800	3,5	1370	40	H9
14000	1,7	8480	85	6,0	14,0	4700	4,4	1070	42	H9

● Available from stock    ○ On request: Tool is available, delivery at short notice

	Outside Ø		Length of the outer bush		Length of the inner bush		Product No.	Material		Article No.	
	D	Tol.	l	Tol.	L	Tol.		Rubber	Metal		
	[mm]		[mm]		[mm]						
40	u10	40	±0,5	46	±0,3	001 18 061	60 NR 11	steel	90037	•	
44	u10	38	±0,5	42	±0,3	001 18 224	40 NR 11	steel	90137	•	
44	u10	38	±0,5	42	±0,5	002 18 919	45 NR 97	aluminium	49040213	○	
44	u10	38	±0,5	42	±0,3	001 18 224	60 NR 11	steel	91711	•	
44	u10	38	±0,5	42	±0,5	002 18 919	60 NR 11	aluminium	49040227	○	
45	u10	30	±0,5	30	±0,3	001 18 181	40 NR 11	steel	2118578	•	
45	u10	30	±0,5	30	±0,3	001 18 181	60 NR 11	steel	91034	•	
45	u11	40	±0,5	46	±0,3	001 18 064	60 NR 11	steel	90039	•	
45	u10	64	±0,5	70	±0,3	001 18 127	60 NR 11	steel	90094	•	
50	u11	40	±0,5	46	±0,3	001 18 065	60 NR 11	steel	90040	•	
50	u11	102	±0,5	115	±0,3	001 18 136	40 NR 11	steel	92150	•	
50	u11	102	±0,5	115	±0,3	001 18 136	60 NR 11	steel	90102	•	
40	u10	40	±0,5	40	±0,3	001 18 130	60 NR 11	steel	90100	•	
40	u10	40	±0,5	40	±0,3	001 18 130	60 NBR 68	steel	477724	○	
40	u10	50	±0,5	56	±0,3	001 18 069	60 NR 11	steel	90043	•	
40	u10	50	±0,5	56	±0,3	001 18 069	60 NBR 68	steel	49004699	○	
42	u10	22	±0,5	23	±0,3	001 18 163	60 NR 11	steel	90955	•	
45	u10	50	±0,5	56	±0,3	001 18 070	60 NR 11	steel	90044	•	
50	u10	50	±0,5	56	±0,3	001 18 072	60 NR 11	steel	90045	•	
55	u10	55	±0,5	60	-1,0	002 18 920	45 NR 97	aluminium	49040214	○	
55	u10	55	±0,5	60	-1,0	002 18 920	60 NR 11	aluminium	49040228	○	
52	u10	48	±0,3	54	±0,3	002 18 005	60 NR 91	steel	49017278	○	
50	u10	60	±0,5	66	±0,3	001 18 075	40 NR 11	steel	90328	•	
50	u10	60	±0,5	66	±0,3	001 18 075	60 NR 11	steel	90046	•	
60	u10	60	±0,5	68	±0,3	001 18 078	60 NR 11	steel	90051	•	
65	u10	70	±0,5	70	±0,3	001 18 220	40 NR 11	steel	91092	•	
65	u10	70	±0,5	70	±0,3	001 18 220	60 NR 11	steel	91318	•	
65	u10	70	±0,5	70	±0,3	001 18 220	60 NBR 68	steel	95300	○	
65	u10	70	±0,5	70	±0,5	002 18 885	60 NR 11	Niro	49004145	○	
55	u10	64	±0,5	72	±0,3	001 18 079	60 NR 11	steel	90052	•	
65	u10	72	±0,5	80	±0,3	001 18 084	60 NR 11	steel	90057	•	
64	u10	80	+0,7	88	±0,3	001 18 117	40 NR 11	steel	49004031	○	
64	u10	80	+0,7	88	±0,3	001 18 117	60 NR 11	steel	90089	•	
65	u11	80	±0,5	88	±0,3	001 18 088	60 NR 11	steel	90060	•	
75	u10	80	±0,5	88	±0,3	001 18 090	60 NR 11	steel	90061	•	
78	u10	45	±0,5	45	±0,5	001 18 285	60 NR 11	steel	91820	•	

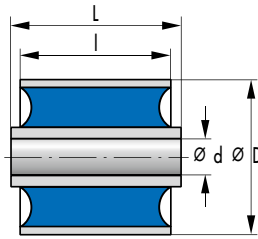

Nominal maxima			Stiffness	Nominal maxima			Stiffness	Nominal maxima			Stiffness	Inside Ø	
Radial			Torsion			Axial							
$F_{r \max}$	$S_{r \max}$	$c_{rad}$	$M_{t \max}$	$\varphi_{\max}$	$C_{tor \varphi}$	$F_{a \max}$	$S_{a \max}$	$c_{ax}$	d	Tol.			
[N]	[mm]	[N/mm]	[Nm]	[°]	[N/mm]	[N]	[mm]	[N/mm]	[mm]				
66700	1,2	55580	185	5,1	36,0	8150	3,6	2260	45	H9			
8700	1,2	7250	90	5,8	16,0	2600	3,0	870	45	H9			
85000	0,9	94440	300	4,4	70,0	9000	2,4	3750	50	H9			
85000	0,9	94440	300	4,4	70,0	9000	2,4	3750	50	H9			
42000	1,7	25450	255	6,7	38,1	9600	4,4	2180	50	H9			
34500	2,0	17250	255	7,1	36,0	10260	6,2	1650	50	H9			
23000	2,9	7930	180	10,5	17,0	5500	7,0	790	50	H9			
55000	2,9	18970	550	10,5	41,0	13000	7,0	1860	50	H9			
15500	1,0	15500	140	4,7	30,0	3300	3,0	1100	58	H9			
33000	1,0	33000	281	4,7	60,0	7000	3,0	2330	58	H9			
52000	1,0	52000	610	5,0	120,0	16000	5,0	3200	70	H9			
128000	1,1	116360	1045	3,3	320,0	14800	2,9	5100	100	H9			
165000	1,5	110000	1850	4,2	440,0	30000	5,0	6000	110	H9			
400000	1,0	400000	3000	3,0	1000,0	43000	4,0	10750	124	H9			
460000	1,0	460000	4600	3,0	1530,0	60000	4,0	15000	124	H9			
260000	2,0	130000	4700	4,7	1000,0	52500	7,0	7500	136	H9			
260000	2,0	130000	4700	4,7	1000,0	52500	7,0	7500	136	H9			

● Available from stock    ○ On request: Tool is available, delivery at short notice

	Outside Ø		Length of the outer bush		Length of the inner bush		Product No.	Material		Article No.	
	D	Tol.	l	Tol.	L	Tol.		Rubber	Metal		
	[mm]		[mm]		[mm]						
	75	±10	90	±0,5	100	±0,3	001 18 093	60 NR 11	steel	90063	•
	80	±10	45	±0,5	45	±0,3	001 18 297	60 NR 11	steel	91424	•
	80	±10	100	±0,5	110	±0,5	001 18 095	60 NR 11	steel	90066	•
	80	±10	100	±0,5	110	±0,5	001 18 095	60 NBR 68	steel	93394	○
	95	±10	100	±0,5	110	±0,3	001 18 360	60 NR 11	steel	90900	•
	100	±10	100	±0,5	110	±0,3	001 18 097	60 NR 11	steel	90070	•
	125	±11	138	±0,2	195	±0,3	001 18 102	40 NR 11	steel	96921	•
	125	±11	138	±0,2	195	±0,3	001 18 102	60 NR 11	steel	96141	•
	93	±11	85	±0,5	95	±0,3	001 18 141	45 NR 11	steel	49039427	○
	93	±11	85	±0,5	95	±0,3	001 18 141	60 NR 11	steel	90106	•
	126	±10	111	±0,5	120	±0,3	001 18 318	60 NR 11	steel	92770	•
	140	±11	110	±0,5	120	±0,3	001 18 772	60 NR 11	steel	96165	•
	160	±11	170	±0,8	180	±0,5	001 18 802	60 NR 11	steel	96246	•
	180	±11	220	±0,8	230	±0,5	001 18 805	60 NR 11	steel	96248	•
	180	±11	220	±0,8	230	±0,5	001 18 805	70 NR 11	steel	96247	•
	218	±10	201,6	±0,5	235	±0,3	001 18 531	60 NR 11	steel	93059	•
	218	±10	201,6	±0,5	235	±0,3	001 18 531	60 NBR 68	steel	480706	○

Article list Ultra Bush, eccentric

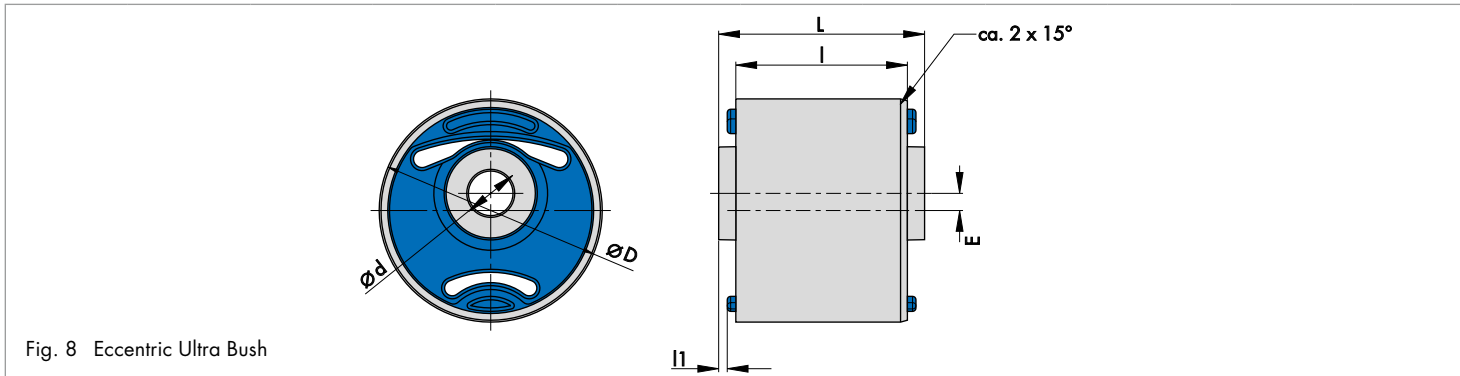

Fig. 8 Eccentric Ultra Bush

Nominal maxima		Stiffness	Nominal maxima		Stiffness	Nominal maxima		Stiffness	Inside $\varnothing$	
Radial			Radial			Axial			d	Tol.
$F_{r \max Z}$	$s_{r \max Z}$	$c_{rad Z}$	$F_{r \max y}$	$s_{r \max Y}$	$c_{rad Y}$	$F_{a \max}$	$S_{a \max}$	$c_{ax}$		
[N]	[mm]	[N/mm]	[Nm]	[°]	[N/mm]	[N]	[mm]	[N/mm]	[mm]	
600	4	150	740	2	370	200	2,5	80	13	$\pm 0,5$
760	4	190	930	2	420	238	2,5	95	13	$\pm 0,5$
920	4	230	1120	2	560	275	2,5	110	13	$\pm 0,5$
1600	5	320	2200	2	1100	1050	5,0	210	25	$\pm 0,2$
1700	5	340	2800	2	1400	1100	5,0	220	25	$\pm 0,2$
1100	5	220	1380	2	690	650	5,0	130	25	$\pm 0,2$
3000	5	600	3520	2	1760	1650	5,0	330	25	$\pm 0,2$
4500	5	900	4680	2	2340	2250	5,0	450	25	$\pm 0,2$

- Available from stock
- On request: Tool is available, delivery at short notice

	Outside Ø		No-load eccentricity in Z direction	Length of the outer bush		Length of the inner bush		Axial rubber stop	Product No.	Material		Article No.			
	D	Tol.		E	L	Tol.	L			Tol.	l1			Rubber	Metal
	[mm]			[mm]	[mm]		[mm]								
	65	±10	5	50	±0,5	60	±0,5	2,5	002 18 960	35 NR 11	steel	49040515	○		
	65	±10	5	50	±0,5	60	±0,5	2,5	002 18 960	40 NR 11	steel	49040516	○		
	65	±10	5	50	±0,5	60	±0,5	2,5	002 18 960	45 NR 11	steel	49040517	○		
	100	+0,22	7	70	±0,5	85	±0,5	without	002 18 937	48 NR 11	steel	49026595	○		
	100	+0,22	7	70	±0,5	85	±0,5	without	002 18 937	48 AEM 33	steel	49040286	○		
	100	+0,22	7	70	±0,5	85	±0,5	without	002 18 937	40 NR 11	steel	49041844	○		
	100	+0,22	7	70	±0,5	85	±0,5	without	002 18 937	60 NR 11	steel	49041846	○		
	100	+0,22	7	70	±0,5	85	±0,5	without	002 18 937	70 NR 11	steel	49041847	○		



## Spherical Mount

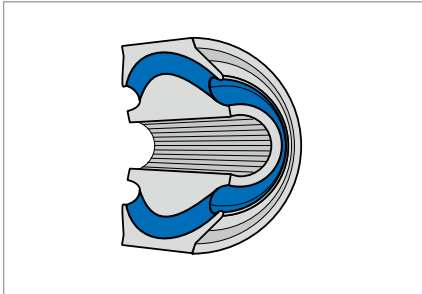

Fig. 1 Spherical Mount

### Material

Standard material	Hardness
Natural rubber	50, 60, 65, 70 Shore A

### Operating conditions

Radial forces	1200 N ... 46000 N	Maximum permissible force
Axial forces	1600 N ... 20000 N	Maximum permissible force
Max. temperature	up to + 60 °C, transient up to +80 °C	
Min. temperature	up to -45 °C	

### Product description

Spherical mounts, as the name suggests, are spherical bushes capable of absorbing axial, radial and torsional movements and cardanic deflections.

### Product advantages

- Maintenance-free articulation
- Reduced settling under radial load
- Increased cardanic loading
- Allowing twist in all directions
- RoHS-compliant.

### Application

Spherical mounts are ideal vibration-control components for articulations that are subjected to twisting in all directions. The mounts are primarily used in bearings, brake levers and steering gears in buses and trucks as well as in reaction-support links in industrial applications.

## Material

Standard material	Hardness
Natural rubber	50, 60, 65, 70 Shore A

## Operating conditions

Radial forces	1200 N ... 46000 N	Maximum permissible force
Axial forces	1600 N ... 20000 N	Maximum permissible force
Max. temperature	up to +60 °C, transient up to +80 °C	
Min. temperature	up to -45 °C	

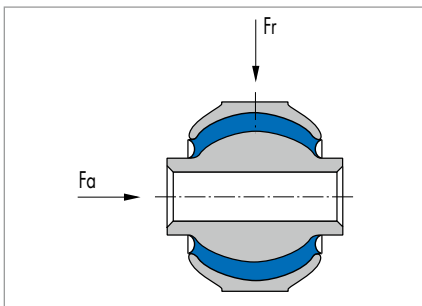

Fig. 2 Primary load directions

Spherical mounts are generally stiffer in the radial direction than in the axial direction and permit angular deflections of 4°–9° for all three spatial axes.

## Design notes

This component consists of an inner ball and an outer spherical shell; the joining element is a vulcanised elastomer insert between ball and shell.

Spherical mounts have a preloaded rubber element, so, as is the case with Ultra Bushes, the mount can be calibrated (see the description of Ultra Bushes) for extended durability.

## Fitting & installation

- Individual components permit slight adjustment to allow for in-situ planar or angular offset
  - If possible, utilise the entire cylindrical surface of the outer sleeve as the bearing surface for spherical mounts
  - If the inner stud has threaded ends, ensure full-surface contact of the flats in the threaded fastener
  - If the inner sleeve is thin, if possible, utilise the entire cylindrical inner face of the inner-sleeve bore as the bearing surface of the spherical mount
  - Always apply installation and removal press-fit forces uniformly to the end faces of the precision sleeves.
- As a rule, spherical mounts are designed for press fitting of the outer metal part and have a threaded fastener on the inner metal part
  - Alternatively, the inner metal ball can be designed to push onto a stud for preloading against a collar or for press-fitting on a stud

Article list

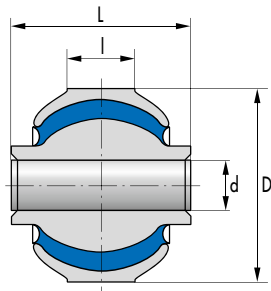

Fig. 3 Spherical Mounts 054 18 036, 054 18 068, 054 18 191, 054 18 070

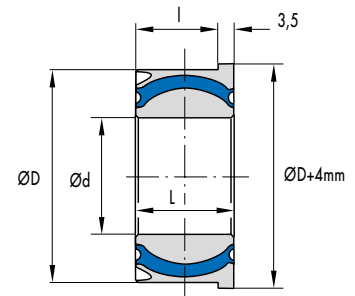

Fig. 4 Spherical Mount 054 18 163

Nominal maxima		Stiffness	Nominal maxima		Stiffness	Nominal maxima		Stiffness	Nominal maxima		Stiffness	Inside Ø		Outside Ø	
Radial			Axial			Torsion			Cardanic			d	Tol.	D	Tol.
F <sub>r max</sub>	S <sub>r max</sub>	C <sub>r</sub>	F <sub>a max</sub>	S <sub>a max</sub>	C <sub>a</sub>	M <sub>t max</sub>	φ <sub>t max</sub>	c <sub>t</sub>	M <sub>k max</sub>	φ <sub>k max</sub>	c <sub>k</sub>				
[N]	[mm]	[N/mm]	[N]	[mm]	[N/mm]	[Nm]	[°]	[Nm/°]	[Nm]	[°]	[Nm/°]	[mm]		[mm]	
1200	0,6	2000	3600	1,5	2400	25	7,0	4	25	4,0	10	16	H9	45,0	u6
18700	0,8	23380	11300	2,0	5650	75	9,0	10	80	4,0	20	16	H8	65,0	r8
20500	0,6	34170	4100	1,1	3730	108	4,5	20	70	4,5	20	20	H8	75,0	r8
46000	0,7	65710	20000	1,2	16670	266	8,0	30	160	4,0	40	30	H8	90,0	r8
28000	0,7	40000	4800	1,5	3200	440	5,0	90	280	5,0	60	53	H7	100,0	r8
35000	0,7	50000	6000	1,5	4000	550	5,0	110	330	5,0	70	53	H7	100,0	r8
25000	0,8	31250	1600	4,0	400	140	6,0	20	120	3,0	40	-	-	66,67	p7
25000	0,3	75760	4000	4,0	1000	45	6,0	10	100	3,0	30	-	-	66,67	p7
25000	0,3	75760	4000	4,0	1000	45	6,0	10	100	3,0	30	-	-	66,67	p7

● Available from stock    ○ On request: Tool is available, delivery at short notice

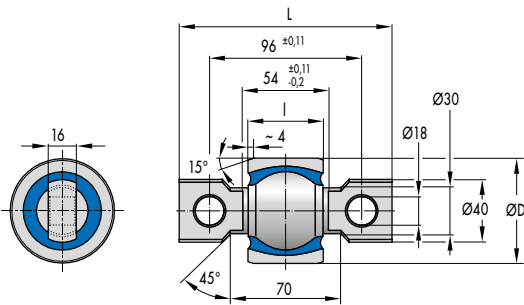

Fig. 5 Spherical Mount 054 18 710, 054 18 711

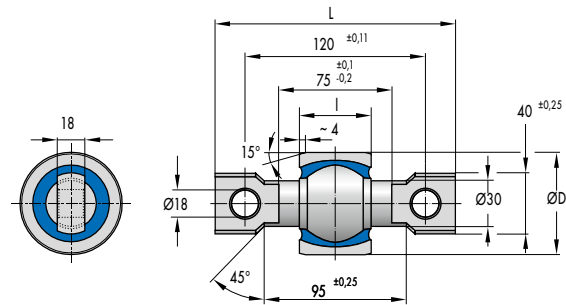

Fig. 5 Spherical Mount 054 18 732

	Length of inside component		Length of outside component		Product No.	Material	Corrosion protection	Article No.	
	L	Tol.	l	Tol.					
	[mm]	[mm]	[mm]	[mm]					
	42	-0,10	35,0	±0,3	5418 036	60 NR 11	Slightly oiled	90721	•
	60	-0,20	32,0	±0,3	5418 068	60 NR 11	Slightly oiled	92525	•
	50	±0,20	46,0	+1,0	5418 191	65 NR 11	Slightly oiled	93644	•
	76	-0,20	45,0	±0,3	5418 070	60 NR 11	Slightly oiled	92041	•
	50	-0,20	46,5/50,0	±0,3	5418 163	65 NR 13	Slightly oiled	93418	•
	50	-0,20	46,5/50,0	±0,3	5418 163	70 NR 11	Slightly oiled	93643	•
	135	±0,30	47,6	±0,3	5418 710	50 NR 11	Slightly oiled	465259	○
	135	±0,30	47,6	±0,3	5418 711	65 NR 13	Fe//Zn8//C	462023	○
	160	±0,25	47,6	±0,3	5418 732	65 NR 13	Fe//Zn8//C	479059	○

## Conical Mount

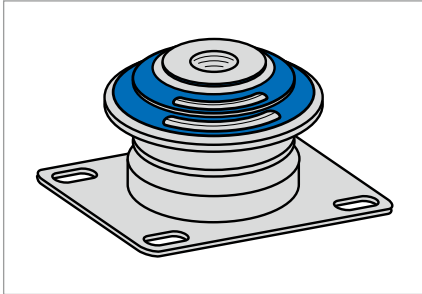

Fig. 1 Conical Mount

### Product description

Conical mounts damp vertical vibrations, isolate against structure-borne noise and can simultaneously accept large horizontal forces (e.g. deceleration forces under braking). Conical mounts are delivered without washers as standard. The suitable washers and stops can be found in the section on Washers and Centering Washers as well as in Rubberised Stop Washers.

### Product advantages

- Long service life
- Optimum settling
- Auto-centring under axial load
- RoHS-compliant.

### Application

Conical mounts are ideal, resilient connecting elements for mounting engines, driven machinery and superstructures for both stationary operation and in vehicles and ships.

### Material

Standard material	Hardness
Natural rubber NR 11, NR 39	35, 40, 45, 50, 55, 60, 65, 70, 76, 80 Shore A
Acrylonitrile-butadiene rubber NBR 68	55, 65, 70 Shore A
Ethylene-acrylate rubber AEM 33	55, 60 Shore A

### Operating conditions

<b>Axial forces</b>	500 N ... 30000 N	Maximum permissible force
<b>Max. temperature</b>	up to 60 °C, transient up to +80 °C	
<b>Min. temperature</b>	up to -45 °C	

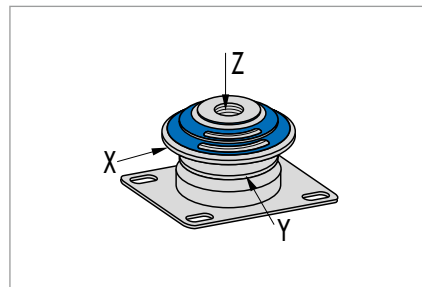

Fig. 2 Primary load directions

Properly positioned conical mounts for mounting engines lightly cushions the torque which reduces the vibrations introduced into the anchorages and thus contributes to a better running smoothness. The weight should primarily be absorbed in the longitudinal axis (+Z). The range of conical mounts offers a large number of different designs for the optimal solution of all conceivable application/installation cases. Tear-off or separation protection is also thus possible.

### Design notes

The mount configuration is manufactured from an inner and outer metal part. The outer metal part has a multi-hole flange and the inner metal part has a through-hole with or without a thread or a tapped blind hole. Both tapered metal parts are connected in tapered parallel orientation by an elastomer insert.

### Fitting & installation

- The conical mounts are designed to be secured by means of threaded fasteners
- Individual components permit slight adjustment to allow for in-situ offset
- It is important to ensure that the mating faces of the frame and the mass carried by the mount are flat and smooth
- Ensure that the underside of the flange is in full-surface contact with the mating face of the frame anchorage
- Position the mount relative to the static load in such a way that the inner metal part and the flange are preloaded relative to each other
- Avoid tensile loads or use the stop and centering washers to limit these loads (see the section on stop washers).

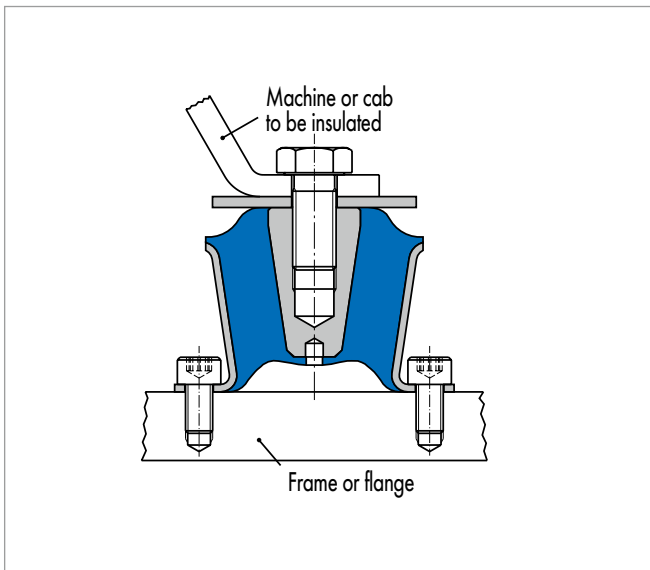

Fig. 3 Secured by threaded fasteners in base

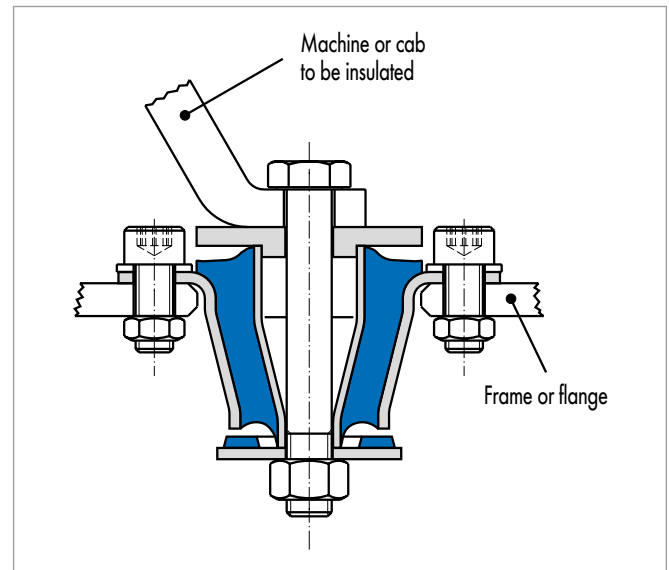

Fig. 4 Secured by threaded fasteners in flange

Article list

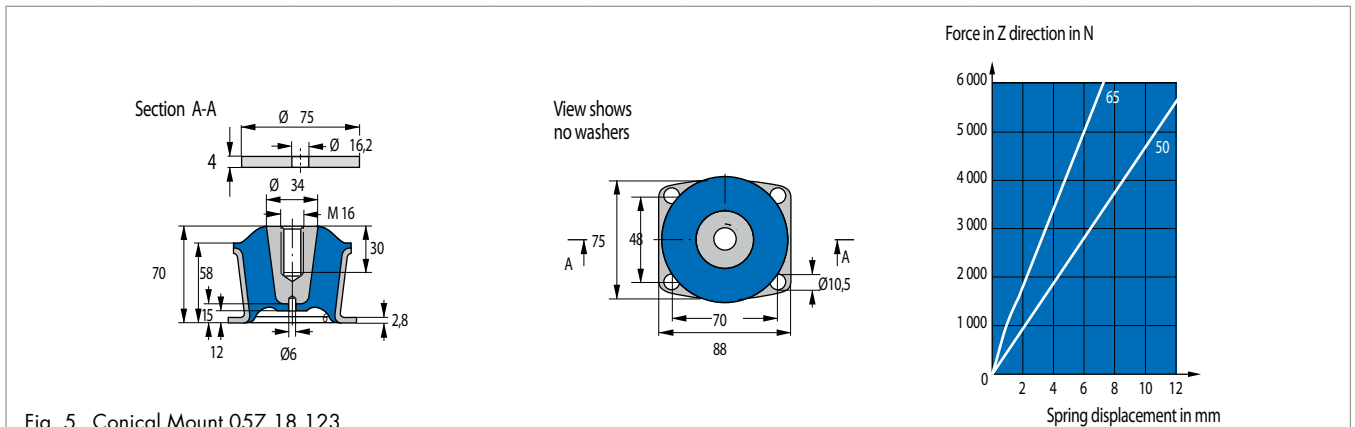

Fig. 5 Conical Mount 057 18 123

Nominal maxima		Stiffness	Nominal maxima		Stiffness	Nominal maxima		Stiffness	Window	Product No.	Material	Article No.	
Axial			Radial			Radial							
$F_z$ max	$s_z$ max	$c_z$	$F_x$ max	$s_x$ max	$c_x$	$F_y$ max	$s_y$ max	$c_y$					
[N]	[mm]	[N/mm]	[N]	[mm]	[N/mm]	[N]	[mm]	[N/mm]					
3570	7	500	1750	1,5	870	1750	1,5	870	without	5718 123	50 NR 11	93270	•
6000	7	850	2700	1,5	1350	2700	1,5	1350	without	5718 123	65 NR 11	91790	•

● Available from stock ○ On request: Tool is available, delivery at short notice

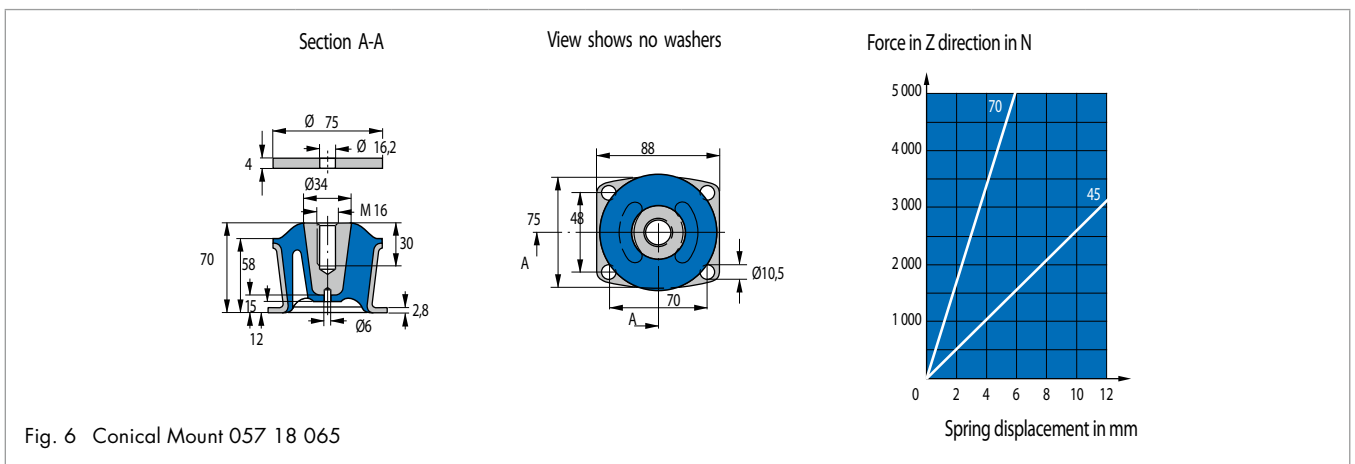

Fig. 6 Conical Mount 057 18 065

Nominal maxima		Stiffness	Nominal maxima		Stiffness	Nominal maxima		Stiffness	Window	Product No.	Material	Article No.	
Axial			Radial			Radial							
$F_z$ max	$s_z$ max	$c_z$	$F_x$ max	$s_x$ max	$c_x$	$F_y$ max	$s_y$ max	$c_y$					
[N]	[mm]	[N/mm]	[N]	[mm]	[N/mm]	[N]	[mm]	[N/mm]					
1960	7	270	1125	1,5	750	560	1,5	370	with	5718 065	45 NR 11	90822	•
6200	7	880	3250	1,5	1600	1800	1,5	900	with	5718 065	70 NR 11	92448	•

● Available from stock ○ On request: Tool is available, delivery at short notice



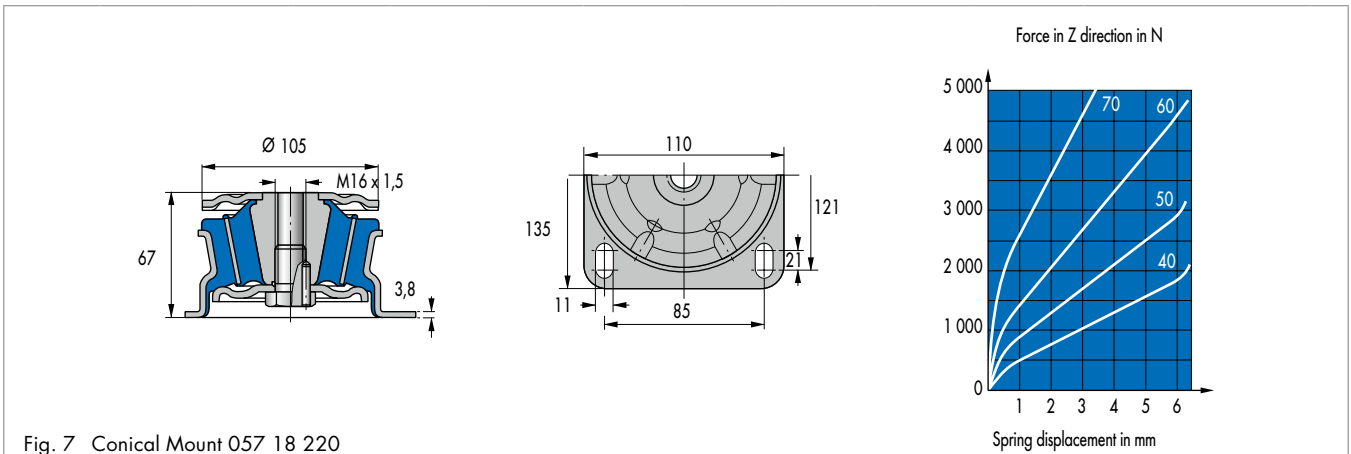

Fig. 7 Conical Mount 057 18 220

Nominal maxima		Stiffness	Nominal maxima		Stiffness	Nominal maxima		Stiffness	Window	Product No.	Material	Article No.	
Axial			Radial			Radial							
F <sub>z max</sub>	s <sub>z max</sub>	c <sub>z</sub>	F <sub>x max</sub>	s <sub>x max</sub>	c <sub>x</sub>	F <sub>y max</sub>	s <sub>y max</sub>	c <sub>y</sub>					
[N]	[mm]	[N/mm]	[N]	[mm]	[N/mm]	[N]	[mm]	[N/mm]					
1400	4,5	260	1500	2	750	1500	2	750	without	5718 220	40 NR 11	91067	•
2100	4,0	390	2200	2	1100	2200	2	1100	without	5718 220	50 NR 11	91374	•
3000	3,5	610	3400	2	1700	3400	2	1700	without	5718 220	60 NR 11	93876	•
4200	2,7	1000	5200	2	2600	5200	2	2600	without	5718 220	70 NR 11	91230	•
6300	2,7	1500	7800	2	3900	7800	2	3900	without	5718 220	80 NR 11	49018753	○

● Available from stock   ○ On request: Tool is available, delivery at short notice

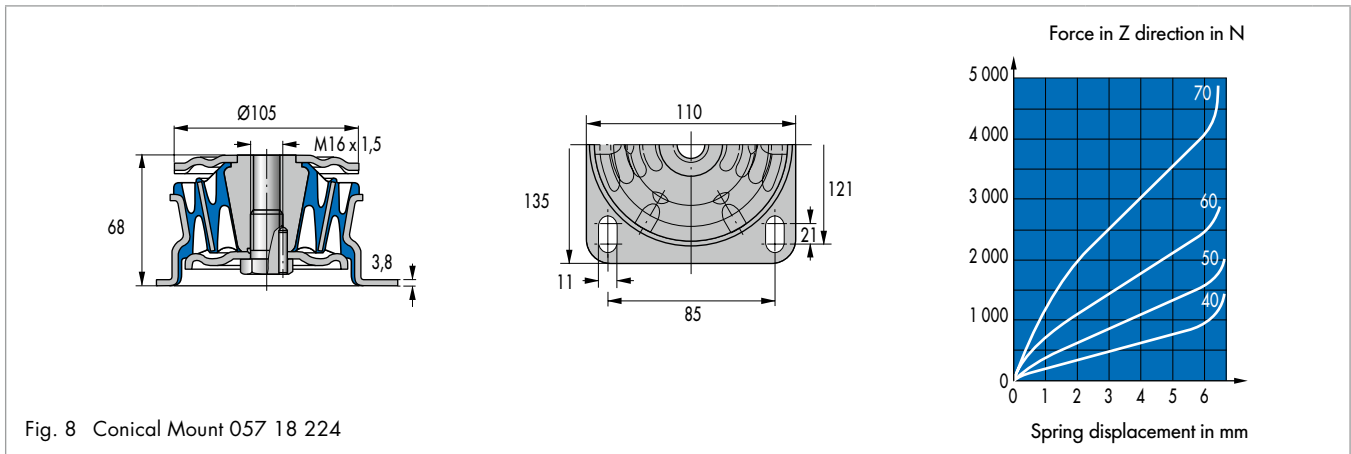

Fig. 8 Conical Mount 057 18 224

Nominal maxima		Stiffness	Nominal maxima		Stiffness	Nominal maxima		Stiffness	Window	Product No.	Material	Article No.	
Axial			Radial			Radial							
F <sub>z max</sub>	s <sub>z max</sub>	c <sub>z</sub>	F <sub>x max</sub>	s <sub>x max</sub>	c <sub>x</sub>	F <sub>y max</sub>	s <sub>y max</sub>	c <sub>y</sub>					
[N]	[mm]	[N/mm]	[N]	[mm]	[N/mm]	[N]	[mm]	[N/mm]					
700	4,5	140	1200	2	600	600	2	300	with	5718 224	40 NR 11	91376	•
1100	4,0	220	1800	2	900	900	2	450	with	5718 224	50 NR 11	91076	•
1600	3,5	330	2800	2	1400	1400	2	700	with	5718 224	60 NR 11	91491	•
2400	2,7	500	4400	2	2200	2200	2	1100	with	5718 224	70 NR 11	91381	•

● Available from stock   ○ On request: Tool is available, delivery at short notice

Article list

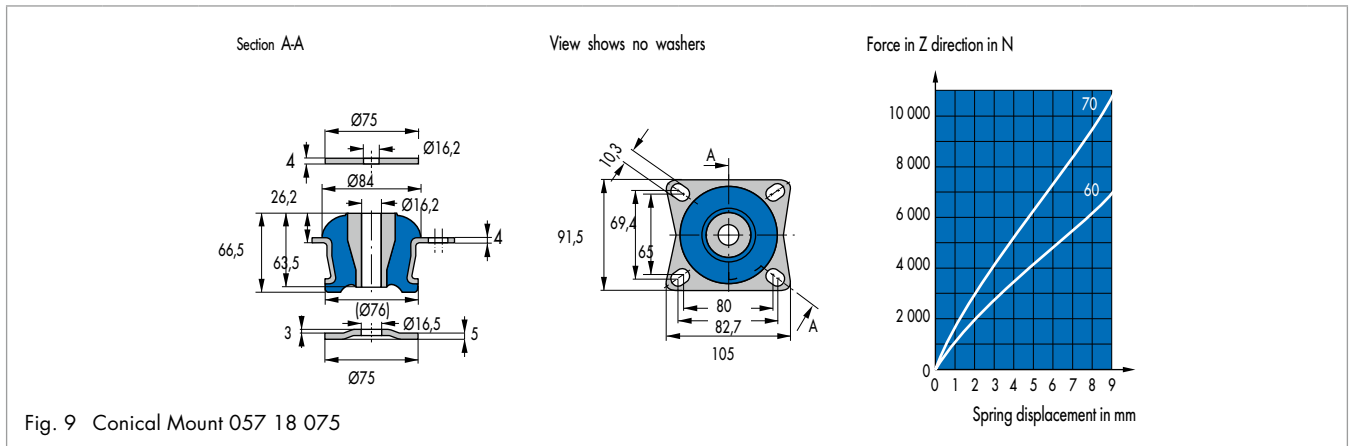

Fig. 9 Conical Mount 057 18 075

Nominal maxima		Stiffness	Nominal maxima		Stiffness	Nominal maxima		Stiffness	Win- dow	Product No.	Material	Article No.	
Axial		Radial			Radial								
$F_z$ max	$s_z$ max	$c_z$	$F_x$ max	$s_x$ max	$c_x$	$F_y$ max	$s_y$ max	$c_y$					
[N]	[mm]	[N/mm]	[N]	[mm]	[N/mm]	[N]	[mm]	[N/mm]					
3400	8	400	1200	1,5	800	1200	1,5	800	without	5718 075	45 NR 11	93385	•
6200	8	670	2100	1,5	1400	2100	1,5	1400	without	5718 075	60 NR 11	91829	•
9500	8	1070	3360	1,5	2240	3360	1,5	2240	without	5718 075	70 NR 11	90863	•
18400	8	2100	6450	1,5	4300	6450	1,5	4300	without	5718 075	76 NR 39	510004	•

• Available from stock    ○ On request: Tool is available, delivery at short notice

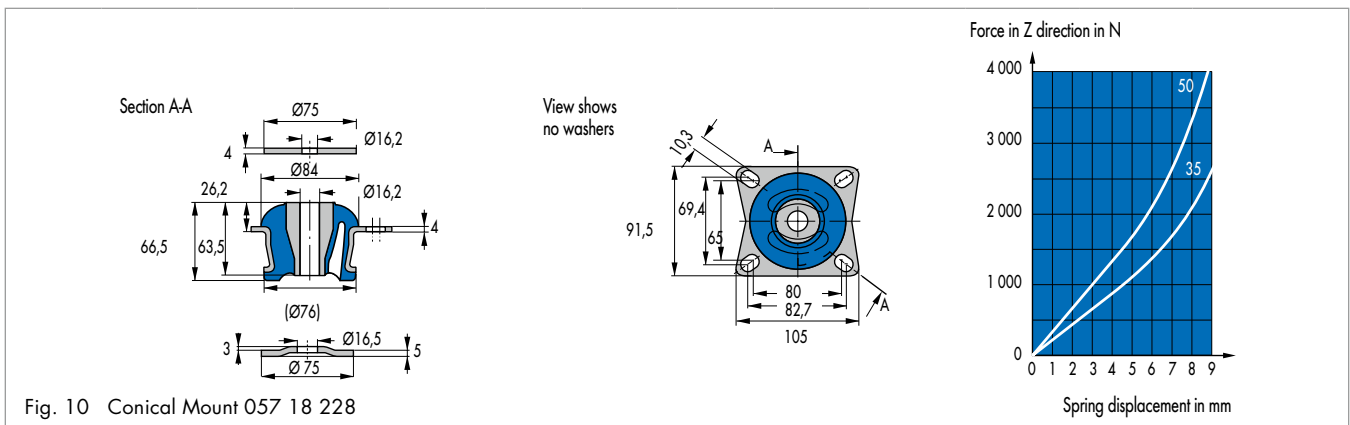

Fig. 10 Conical Mount 057 18 228

Nominal maxima		Stiffness	Nominal maxima		Stiffness	Nominal maxima		Stiffness	Win- dow	Product No.	Material	Article No.	
Axial		Radial			Radial								
$F_z$ max	$s_z$ max	$c_z$	$F_x$ max	$s_x$ max	$c_x$	$F_y$ max	$s_y$ max	$c_y$					
[N]	[mm]	[N/mm]	[N]	[mm]	[N/mm]	[N]	[mm]	[N/mm]					
2100	8	210	660	1,5	440	270	1,5	180	with	5718 228	35 NR 11	93641	•
3300	8	340	1335	1,5	890	540	1,5	360	with	5718 228	50 NR 11	93642	•
6100	8	600	2400	1,5	1600	1050	1,6	700	with	5718 228	65 NR 11	91405	•

• Available from stock    ○ On request: Tool is available, delivery at short notice

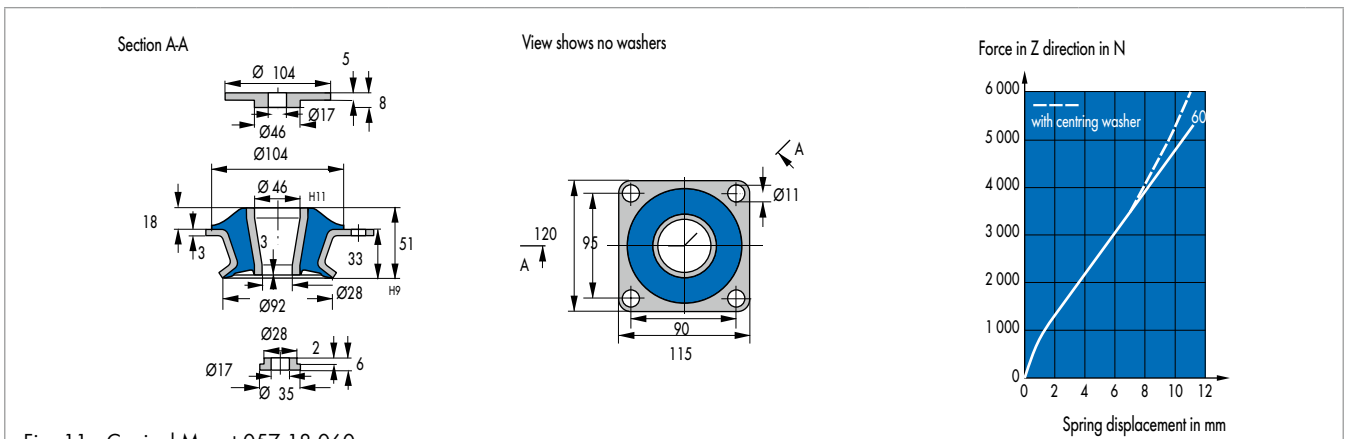

Fig. 11 Conical Mount 057 18 060

Nominal maxima		Stiffness	Nominal maxima		Stiffness	Nominal maxima		Stiffness	Win- dow	Product No.	Material	Article No.	
Axial			Radial			Radial							
$F_z$ max	$s_z$ max	$c_z$	$F_x$ max	$s_x$ max	$c_x$	$F_y$ max	$s_y$ max	$c_y$					
[N]	[mm]	[N/mm]	[N]	[mm]	[N/mm]	[N]	[mm]	[N/mm]					
2200	10,5	200	3600	4	900	4000	4	1000	without	5718 060	40 NR 11	93900	•
3400	10,5	300	5200	4	1300	6000	4	1500	without	5718 060	50 NR 11	91479	•
4200	10,5	400	6800	4	1700	7200	4	1800	without	5718 060	55 NBR 38	509731	•
5000	10,5	430	8000	4	2000	8800	4	2200	without	5718 060	60 NR 11	90465	•
6000	10,5	500	9600	4	2400	10400	4	2600	without	5718 060	65 NBR 68	479685	•
7500	10,5	600	12000	4	3000	13200	4	3300	without	5718 060	70 NR 11	476214	•

● Available from stock ○ On request: Tool is available, delivery at short notice

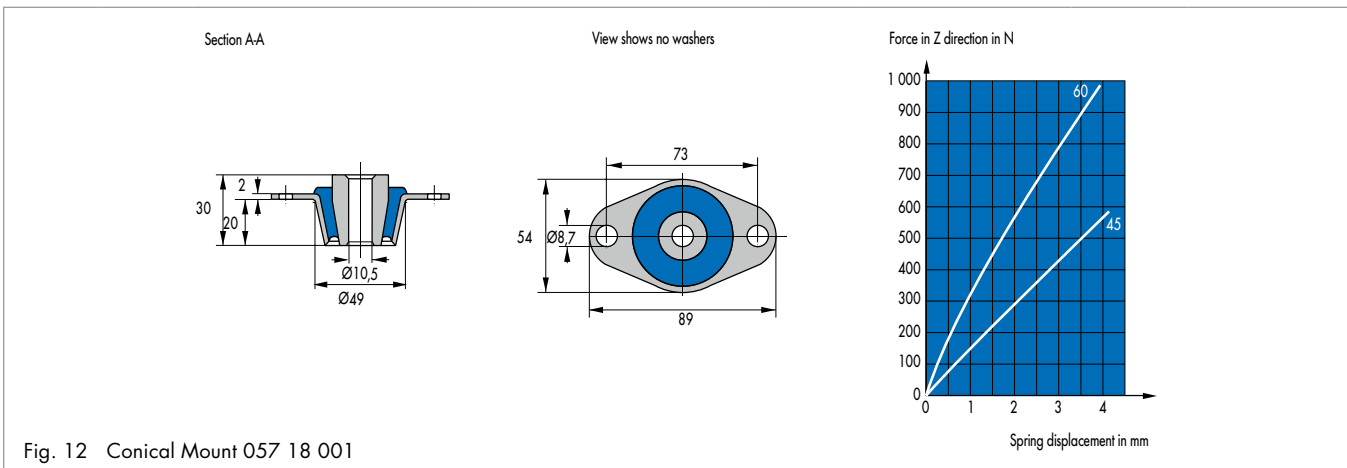

Fig. 12 Conical Mount 057 18 001

Nominal maxima		Stiff- ness	Nominal maxima		Stiff- ness	Nominal maxima		Stiff- ness	Win- dow	Product No.	Material	Article No.	
Axial			Radial			Radial							
$F_z$ max	$s_z$ max	$c_z$	$F_x$ max	$s_x$ max	$c_x$	$F_y$ max	$s_y$ max	$c_y$					
[N]	[mm]	[N/mm]	[N]	[mm]	[N/mm]	[N]	[mm]	[N/mm]					
550	3,5	160	1000	1	1000	1000	1	1000	without	5718 001	45 NR 11	90905	•
900	3,5	260	1800	1	1800	1800	1	1800	without	5718 001	60 NR 11	90810	•
900	3,5	260	1800	1	1800	1800	1	1800	without	5718 001	60 AEM 33	49018563	•
1100	3,5	310	2200	1	2200	2200	1	2200	without	5718 001	70 NR 11	91056	•

● Available from stock ○ On request: Tool is available, delivery at short notice

Article list

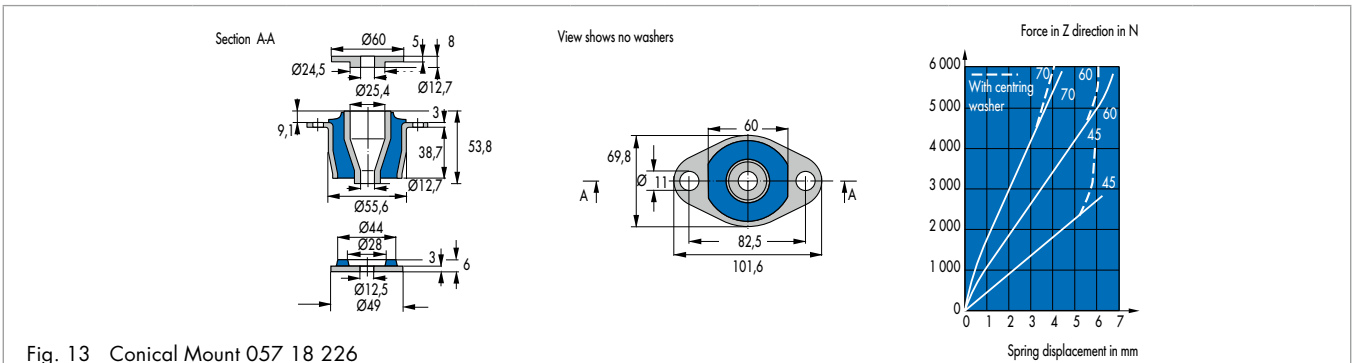

Fig. 13 Conical Mount 057 18 226

Nominal maxima		Stiffness	Nominal maxima		Stiffness	Nominal maxima		Stiffness	Window	Product No.	Material	Article No.	
Axial			Radial			Radial							
$F_z$ max	$s_z$ max	$c_z$	$F_x$ max	$s_x$ max	$c_x$	$F_y$ max	$s_y$ max	$c_y$					
[N]	[mm]	[N/mm]	[N]	[mm]	[N/mm]	[N]	[mm]	[N/mm]					
2000	5	400	1000	1	1000	1000	1	1000	without	5718 226	45 NR 39	2129296	•
2300	5	460	1150	1	1150	1150	1	1150	without	5718 226	45 NR 11	93947	•
3400	5	700	1700	1	1700	1700	1	1700	without	5718 226	55 NBR 68	49019621	•
4200	5	720	1970	1	1970	1970	1	1970	without	5718 226	60 NR 11	93948	•
5200	4	1190	2970	1	2970	2970	1	2970	without	5718 226	70 NR 11	93949	•

● Available from stock ○ On request: Tool is available, delivery at short notice

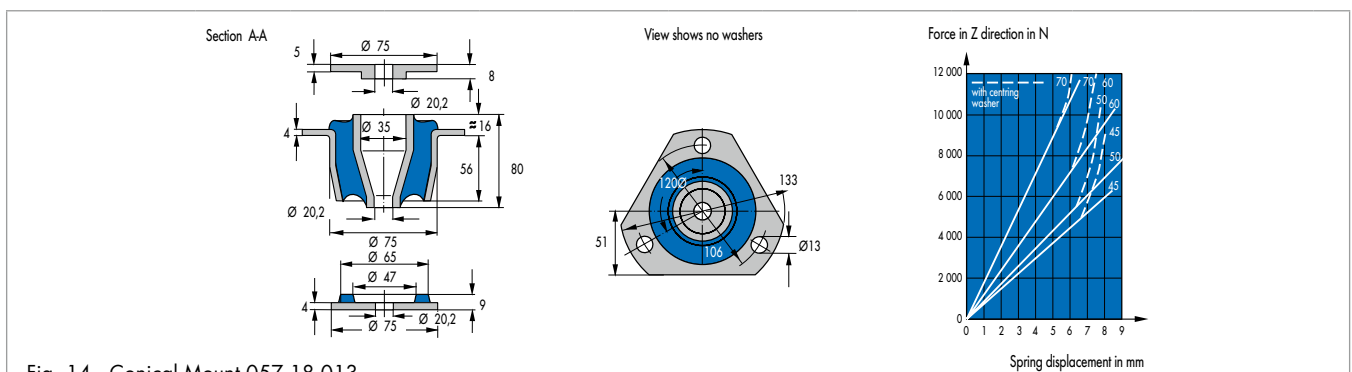

Fig. 14 Conical Mount 057 18 013

Nominal maxima		Stiffness	Nominal maxima		Stiffness	Nominal maxima		Stiffness	Window	Product No.	Material	Article No.	
Axial			Radial			Radial							
$F_z$ max	$s_z$ max	$c_z$	$F_x$ max	$s_x$ max	$c_x$	$F_y$ max	$s_y$ max	$c_y$					
[N]	[mm]	[N/mm]	[N]	[mm]	[N/mm]	[N]	[mm]	[N/mm]					
3300	5,5	600	7400	2,5	2960	7400	2,5	2960	without	5718 013	45 NR 11	90697	•
3800	5,5	690	8500	2,5	3400	8500	2,5	3400	without	5718 013	45 NR 39	49029143	•
6500	5,5	1180	9800	2,5	3900	9800	2,5	3920	without	5718 013	50 NR 11	91201	•
7200	5,5	1310	11600	2,5	4600	11600	2,5	4600	without	5718 013	60 NR 39	49029144	•
8500	5,5	1550	13800	2,5	5500	13800	2,5	5500	without	5718 013	60 NR 11	90877	•
9600	5,5	1750	14500	2,5	5800	14500	2,5	5800	without	5718 013	55 AEM 23	500857	•
10000	5,5	1820	12500	2,5	5000	12500	2,5	5000	without	5718 013	70 NR 11	90849	•
10000	5,5	1820	12500	2,5	5000	12500	2,5	5000	without	5718 013	70 NBR 68	511079	•
10100	5,5	1800	16400	2,5	6500	16400	2,5	6500	without	5718 013	65 NBR 68	2129417	•
11100	5,5	2000	13800	2,5	5500	13800	2,5	5500	without	5718 013	76 NR 39	480534	•

● Available from stock ○ On request: Tool is available, delivery at short notice

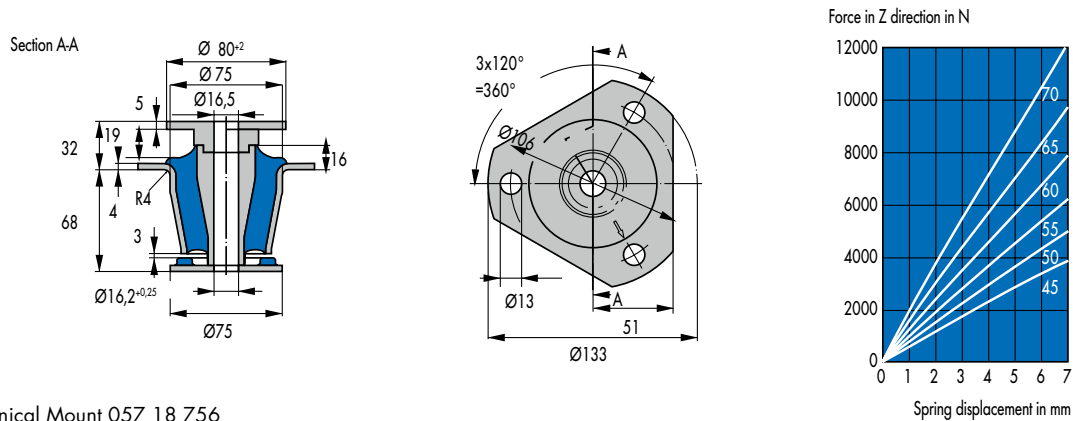

Fig. 15 Conical Mount 057 18 756

Nominal maxima		Stiffness	Nominal maxima		Stiffness	Nominal maxima		Stiffness	Window	Product No.	Material	Article No.	
Axial			Radial			Radial							
$F_z$ max	$s_z$ max	$c_z$	$F_x$ max	$s_x$ max	$c_x$	$F_y$ max	$s_y$ max	$c_y$					
[N]	[mm]	[N/mm]	[N]	[mm]	[N/mm]	[N]	[mm]	[N/mm]					
4800	8	600	6300	3	2100	3300	3	2100	without	5718 756	45 NR 11	511906	○
6400	8	800	9900	3	2850	5250	3	2850	without	5718 756	50 NR 11	2129305	○
8000	8	1000	14400	3	3500	7500	3	3500	without	5718 756	55 NR 11	2129306	○
10000	8	1250	20700	3	4400	10800	3	4400	without	5718 756	60 NR 11	2129307	○
12400	8	1550	26100	3	5450	13650	3	5450	without	5718 756	65 NR 11	2129308	○
15600	8	1950	32400	3	6850	16950	3	6850	without	5718 756	70 NR 11	2129309	○

● Available from stock ○ On request: Tool is available, delivery at short notice

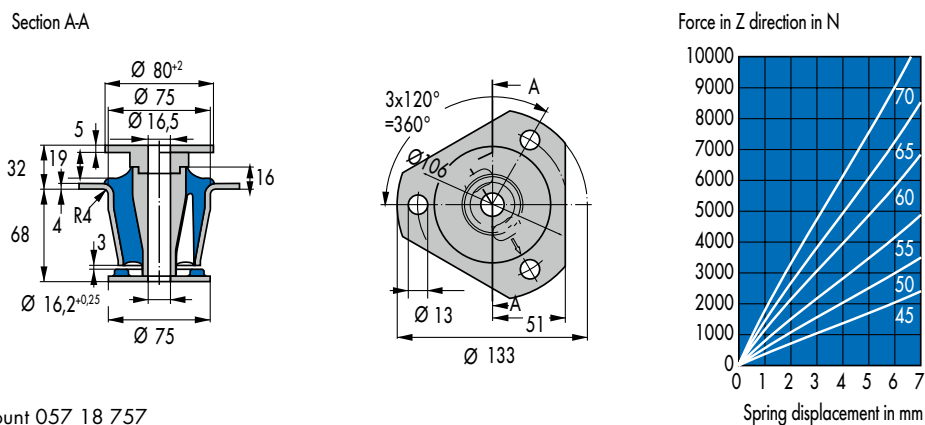

Fig. 16 Conical Mount 057 18 757

Nominal maxima		Stiffness	Nominal maxima		Stiffness	Nominal maxima		Stiffness	Window	Product No.	Material	Article No.	
Axial			Radial			Radial							
$F_z$ max	$s_z$ max	$c_z$	$F_x$ max	$s_x$ max	$c_x$	$F_y$ max	$s_y$ max	$c_y$					
[N]	[mm]	[N/mm]	[N]	[mm]	[N/mm]	[N]	[mm]	[N/mm]					
2800	8	350	1140	3	2100	1140	3	1100	with	5718 757	45 NR 11	511926	●
4400	8	550	1320	3	3300	1320	3	1750	with	5718 757	50 NR 11	2129310	○
6400	8	800	1740	3	4800	1740	3	2500	with	5718 757	55 NR 11	2129311	○
9200	8	1150	2280	3	6900	2280	3	3600	with	5718 757	60 NR 11	2129312	○
11600	8	1450	3150	3	8700	3150	3	4550	with	5718 757	65 NR 11	2129313	○
14400	8	1800	4080	3	10800	4080	3	5650	with	5718 757	70 NR 11	2129314	○

● Available from stock ○ On request: Tool is available, delivery at short notice

Elastomer Dampers

Article list

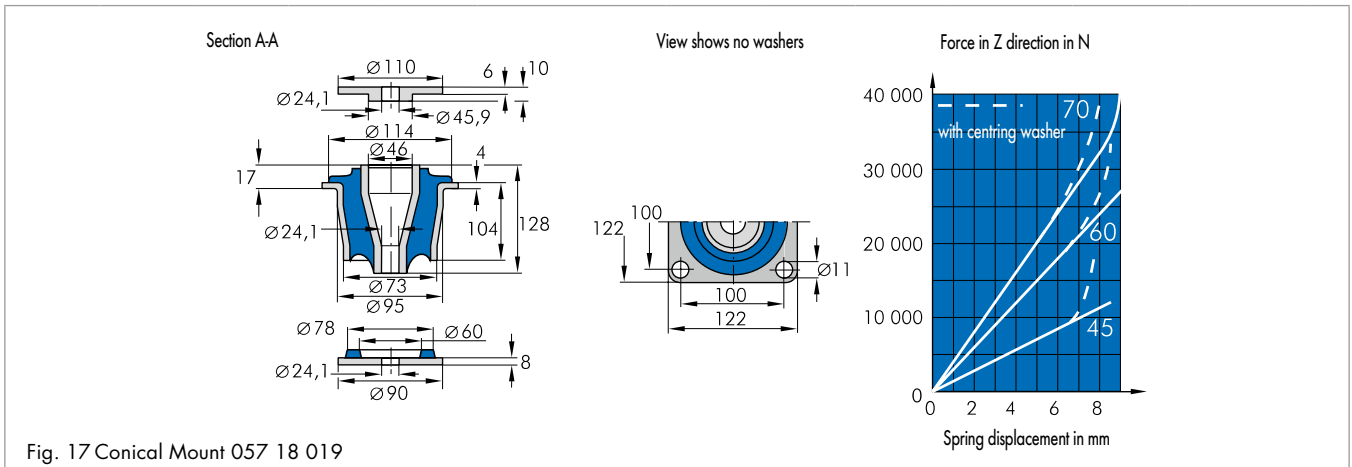

Fig. 17 Conical Mount 057 18 019

Nominal maxima		Stiffness	Nominal maxima		Stiffness	Nominal maxima		Stiffness	Window	Product No.	Material	Article No.	
Axial			Radial			Radial							
$F_z$ max	$s_z$ max	$c_z$	$F_x$ max	$s_x$ max	$c_x$	$F_y$ max	$s_y$ max	$c_y$					
[N]	[mm]	[N/mm]	[N]	[mm]	[N/mm]	[N]	[mm]	[N/mm]					
10000	7	1420	9600	1,5	6400	9600	1,5	6400	without	5718 019	45 NR	91430	•
20000	7	2850	19200	1,5	12800	19200	1,5	12800	without	5718 019	60 NR	90491	•
30000	7	4000	30000	1,5	20000	30000	1,5	20000	without	5718 019	70 NR	91009	•

• Available from stock    ○ On request: Tool is available, delivery at short notice

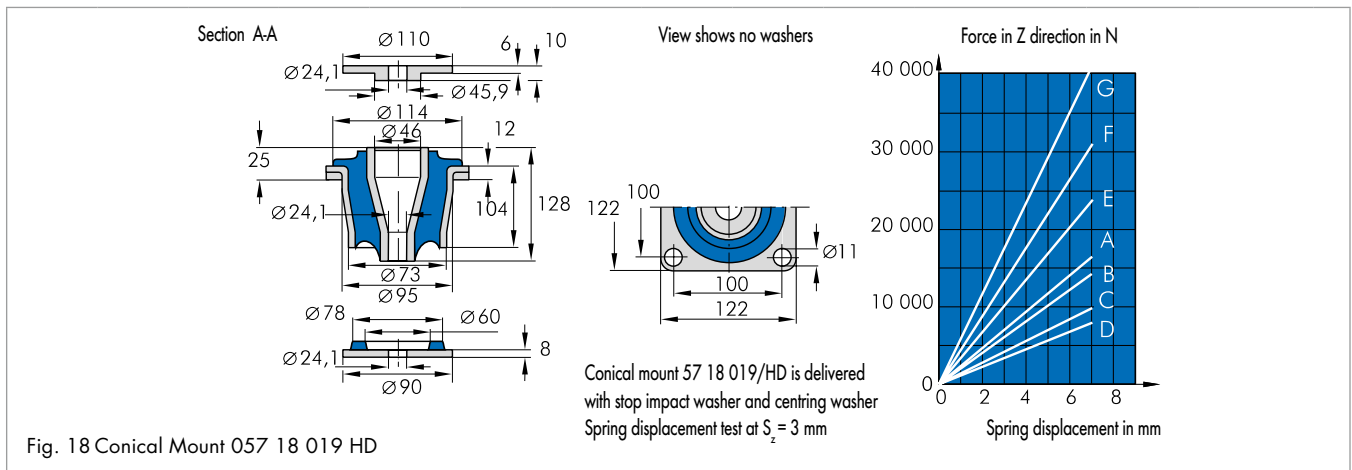

Fig. 18 Conical Mount 057 18 019 HD

Nominal maxima		Stiffness	Nominal maxima		Stiffness	Nominal maxima		Stiffness	Window	Product No.	Material	Article No.	
Axial			Radial			Radial							
$F_z$ max	$s_z$ max	$c_z$	$F_x$ max	$s_x$ max	$c_x$	$F_y$ max	$s_y$ max	$c_y$					
[N]	[mm]	[N/mm]	[N]	[mm]	[N/mm]	[N]	[mm]	[N/mm]					
8900	7	1300	4300	1,5	6500	4300	1,5	6500	without	5718 019/111 HD	D NR	49031009	○
10300	7	1500	5000	1,5	7500	5000	1,5	7500	without	5718 019/111 HD	C NR	49031008	○
14500	7	2100	7000	1,5	10500	7000	1,5	10500	without	5718 019/111 HD	B NR	49031007	○
15600	7	2300	7700	1,5	11500	7700	1,5	11500	without	5718 019/111 HD	A NR	49016406	○
23400	7	3400	11300	1,5	17000	11300	1,5	17000	without	5718 019/111 HD	E NR	49031010	○
30900	7	4200	14000	1,5	21000	14000	1,5	21000	without	5718 019/111 HD	F NR	49055303	○
40800	7	5800	19300	1,5	29000	19300	1,5	29000	without	5718 019/111 HD	G NR	49055304	○

• Available from stock    ○ On request: Tool is available, delivery at short notice

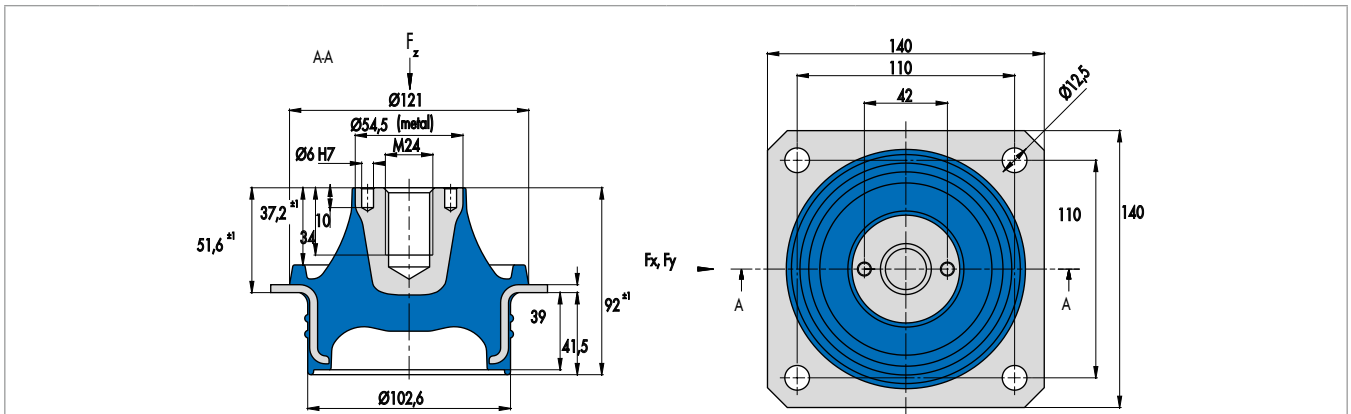

Fig. 19 Conical Mount 057 18 794

Nominal maxima		Stiffness	Nominal maxima		Stiffness	Nominal maxima		Stiffness	Window	Product No.	Material	Article No.	
Axial			Radial			Radial							
$F_z$ max	$s_z$ max	$c_z$	$F_x$ max	$s_x$ max	$c_x$	$F_y$ max	$s_y$ max	$c_y$					
[N]	[mm]	[N/mm]	[N]	[mm]	[N/mm]	[N]	[mm]	[N/mm]					
1900	10	190	1150	5	230	1150	5	230	without	5718 794	40 NR 11	49030359	○
2400	10	240	1450	5	290	1450	5	290	without	5718 794	45 NR 11	49030360	○
3000	10	300	1850	5	370	1850	5	370	without	5718 794	50 NR 11	49030361	○
3700	10	370	2350	5	470	2350	5	470	without	5718 794	55 NR 11	49030402	○
4600	10	460	3000	5	600	3000	5	600	without	5718 794	60 NR 11	49030403	○
5600	10	560	3800	5	760	3800	5	760	without	5718 794	65 NR 11	49030404	○

● Available from stock    ○ On request: Tool is available, delivery at short notice

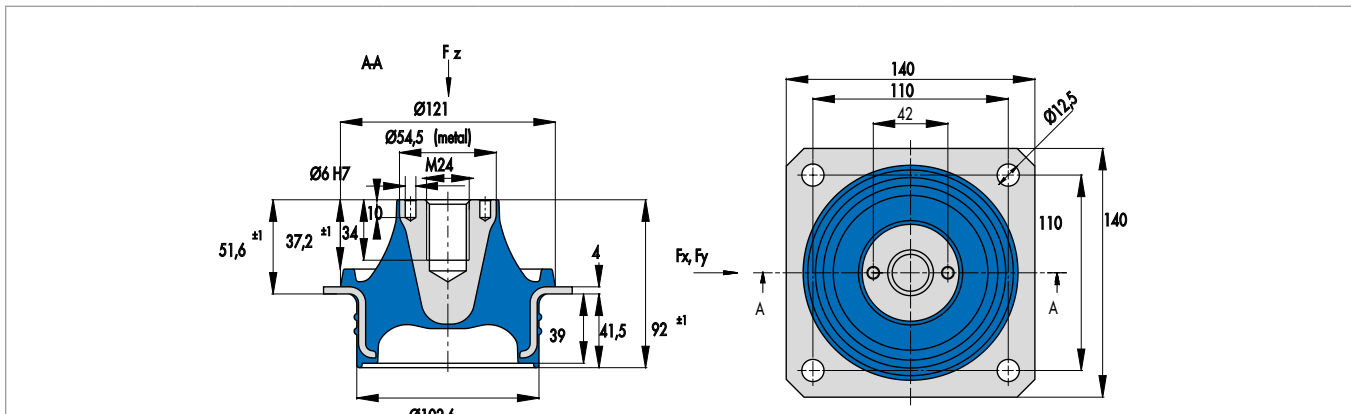

Fig. 20 Conical Mount 057 18 795

Nominal maxima		Stiffness	Nominal maxima		Stiffness	Nominal maxima		Stiffness	Window	Product No.	Material	Article No.	
Axial			Radial			Radial							
$F_z$ max	$s_z$ max	$c_z$	$F_x$ max	$s_x$ max	$c_x$	$F_y$ max	$s_y$ max	$c_y$					
[N]	[mm]	[N/mm]	[N]	[mm]	[N/mm]	[N]	[mm]	[N/mm]					
1900	10	190	1500	5	300	1500	5	300	without	5718 795	40 NR 11	49030405	○
2400	10	240	1950	5	390	1950	5	390	without	5718 795	45 NR 11	49030406	○
3000	10	300	2500	5	500	2500	5	500	without	5718 795	50 NR 11	49030407	○
3600	10	360	3200	5	640	3200	5	640	without	5718 795	55 NR 11	49030408	○
4700	10	470	4150	5	830	4150	5	830	without	5718 795	60 NR 11	49030409	○
8200	10	820	5300	5	1060	5300	5	1060	without	5718 795	65 NR 11	49030410	○

● Available from stock    ○ On request: Tool is available, delivery at short notice

Elastomer Dampers

Article list

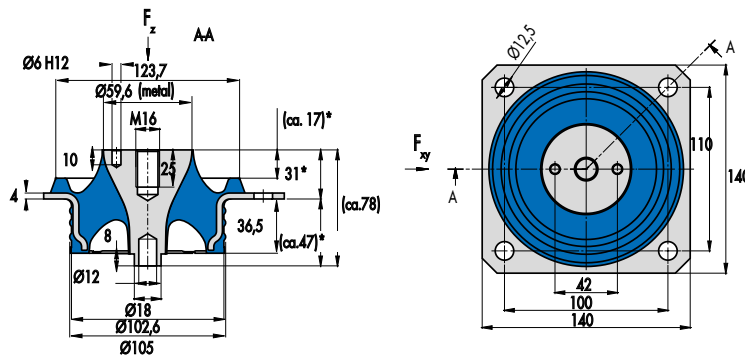

Fig. 21 Conical Mount 057 18 792

Nominal maxima		Stiffness	Nominal maxima		Stiffness	Nominal maxima		Stiffness	Window	Product No.	Material	Article No.	
Axial			Radial			Radial							
$F_z \text{ max}$	$s_z \text{ max}$	$c_z$	$F_x \text{ max}$	$s_x \text{ max}$	$c_x$	$F_y \text{ max}$	$s_y \text{ max}$	$c_y$					
[N]	[mm]	[N/mm]	[N]	[mm]	[N/mm]	[N]	[mm]	[N/mm]					
2600	10	260	1900	5	380	1900	5	380	without	5718 792	40 NR 11	49028584	○
3100	10	310	2200	5	440	2200	5	440	without	5718 792	45 NR 11	49028585	○
3900	10	380	2900	5	580	2900	5	580	without	5718 792	50 NR 11	49028586	○
4700	10	470	3800	5	760	3800	5	760	without	5718 792	55 NR 11	49028587	○
6200	10	600	5250	5	1050	5250	5	1050	without	5718 792	60 NR 11	49028588	○
8000	10	7400	6800	5	1360	6800	5	1360	without	5718 792	65 NR 11	49028589	○

● Available from stock    ○ On request: Tool is available, delivery at short notice

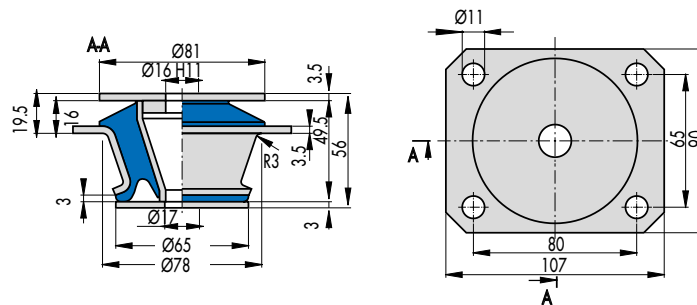

Fig. 22 Conical Mount 057 18 804

Nominal maxima		Stiffness	Nominal maxima		Stiffness	Nominal maxima		Stiffness	Window	Product No.	Material	Article No.	
Axial			Radial			Radial							
$F_z \text{ max}$	$s_z \text{ max}$	$c_z$	$F_x \text{ max}$	$s_x \text{ max}$	$c_x$	$F_y \text{ max}$	$s_y \text{ max}$	$c_y$					
[N]	[mm]	[N/mm]	[N]	[mm]	[N/mm]	[N]	[mm]	[N/mm]					
1300	3	430	1140	3	480	1140	3	480	without	5718 804	45 NR	49041359	○
2600	3	870	2730	3	910	2730	3	910	without	5718 804	60 NR	49041360	○
3600	3	1200	3870	3	1290	3870	3	1290	without	5718 804	70 NR	49041361	○

● Available from stock    ○ On request: Tool is available, delivery at short notice



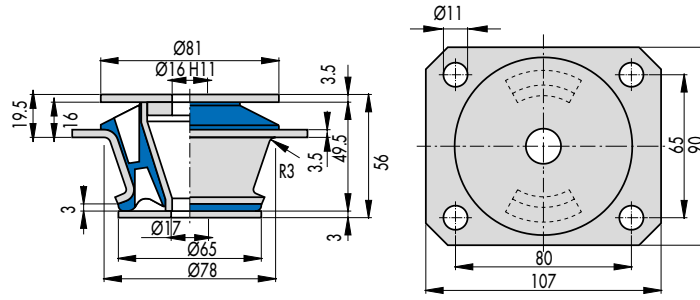

Fig. 23 Conical Mount 057 18 805

Nominal maxima		Stiffness	Nominal maxima		Stiffness	Nominal maxima		Stiffness	Window	Product No.	Material	Article No.	
Axial			Radial			Radial							
$F_z \text{ max}$	$s_z \text{ max}$	$c_z$	$F_x \text{ max}$	$s_x \text{ max}$	$c_x$	$F_y \text{ max}$	$s_y \text{ max}$	$c_y$					
[N]	[mm]	[N/mm]	[N]	[mm]	[N/mm]	[N]	[mm]	[N/mm]					
800	3	270	870	3	290	8700	3	290	with	5718 805	45 NR	49041362	○
1500	3	500	1650	3	550	1650	3	550	with	5718 805	60 NR	49041363	○
2000	3	670	2895	3	965	2895	3	965	with	5718 805	70 NR	49041364	○

● Available from stock    ○ On request: Tool is available, delivery at short notice

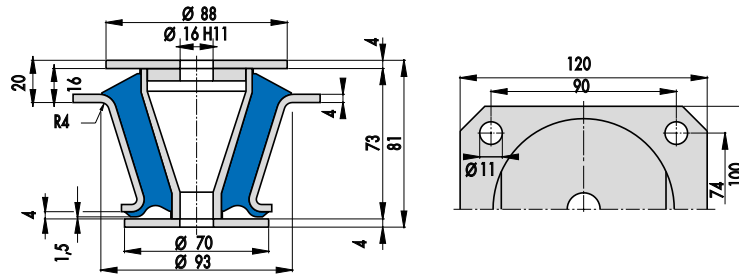

Fig. 24 Conical Mount 057 18 806

Nominal maxima		Stiffness	Nominal maxima		Stiffness	Nominal maxima		Stiffness	Window	Product No.	Material	Article No.	
Axial			Radial			Radial							
$F_z \text{ max}$	$s_z \text{ max}$	$c_z$	$F_x \text{ max}$	$s_x \text{ max}$	$c_x$	$F_y \text{ max}$	$s_y \text{ max}$	$c_y$					
[N]	[mm]	[N/mm]	[N]	[mm]	[N/mm]	[N]	[mm]	[N/mm]					
2000	2	1000	2530	2	1265	2530	2	1265	without	5718 806	45 NR	49041365	○
3800	2	1900	4290	2	2145	4290	2	2145	without	5718 806	60 NR	49041366	○
5800	2	2900	7560	2	3780	7560	2	3780	without	5718 806	70 NR	49041367	○

● Available from stock    ○ On request: Tool is available, delivery at short notice

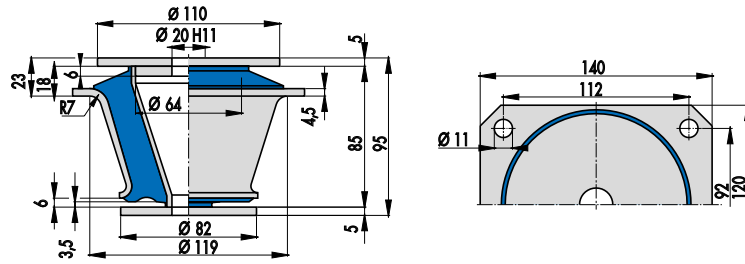

Fig. 25 Conical Mount 057 18 807

Nominal maxima			Stiffness	Nominal maxima			Stiffness	Nominal maxima			Stiffness	Win- dow	Product No.	Material	Article No.	
Axial			Radial			Radial										
$F_{z \max}$	$s_{z \max}$	$c_z$	$F_{x \max}$	$s_{x \max}$	$c_x$	$F_{y \max}$	$s_{y \max}$	$c_y$								
[N]	[mm]	[N/mm]	[N]	[mm]	[N/mm]	[N]	[mm]	[N/mm]								
6000	5	1200	7150	5	1430	7150	5	1430	without	5718 807	45 NR	49041368	○			
11500	5	2300	12350	5	2470	12350	5	2470	without	5718 807	60 NR	49041369	○			
17500	5	3500	20250	5	4050	20250	5	4050	without	5718 807	70 NR	49041370	○			

● Available from stock ○ On request: Tool is available, delivery at short notice

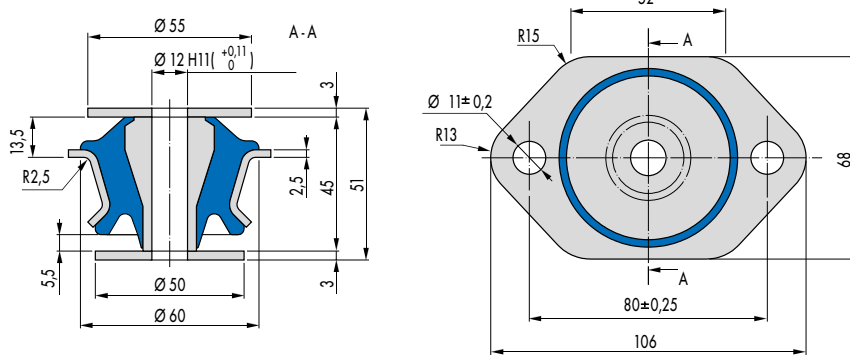
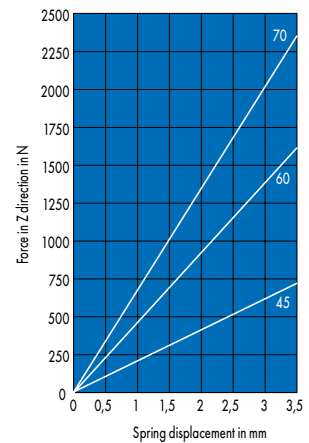

Fig. 26 Conical Mount 057 18 816



Nominal maxima			Stiffness	Nominal maxima			Stiffness	Nominal maxima			Stiffness	Win- dow	Product No.	Material	Article No.	
Axial			Radial			Radial										
$F_{z \max}$	$s_{z \max}$	$c_z$	$F_{x \max}$	$s_{x \max}$	$c_x$	$F_{y \max}$	$s_{y \max}$	$c_y$								
[N]	[mm]	[N/mm]	[N]	[mm]	[N/mm]	[N]	[mm]	[N/mm]								
630	3	210	-	-	-	-	-	-	without	5718 816	45 NR	49047034	○			
1350	3	450	-	-	-	-	-	-	without	5718 816	60 NR	49047035	○			
2000	3	670	-	-	-	-	-	-	without	5718 816	70 NR	49047036	○			

● Available from stock ○ On request: Tool is available, delivery at short notice

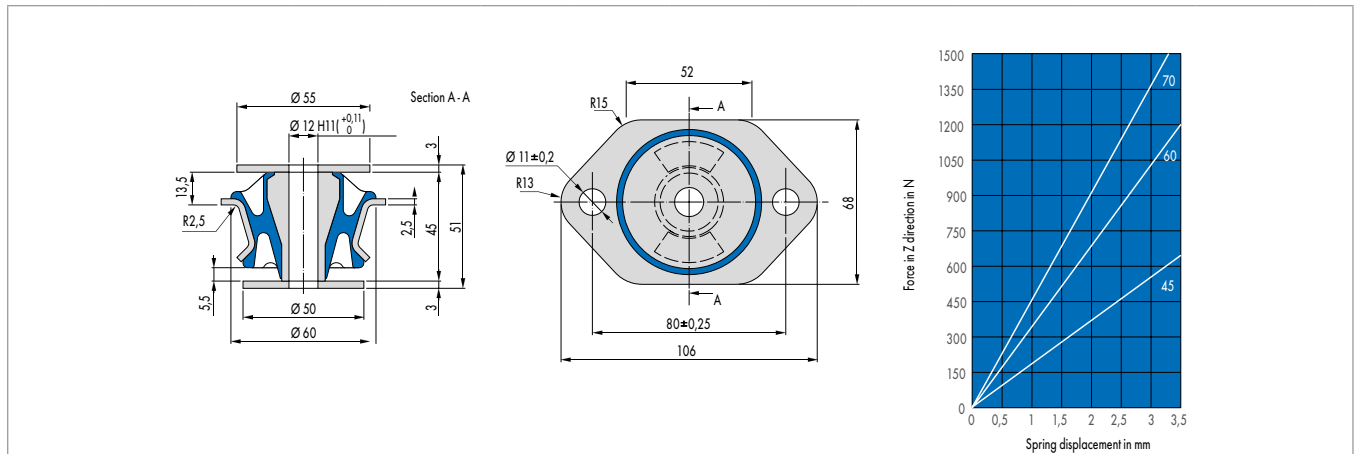

Fig. 27 Conical Mount 057 18 817

Nominal maxima		Stiffness	Nominal maxima		Stiffness	Nominal maxima		Stiffness	Window	Product No.	Material	Article No.	
Axial			Radial			Radial							
$F_{z \max}$	$s_{z \max}$	$c_z$	$F_{x \max}$	$s_{x \max}$	$c_x$	$F_{y \max}$	$s_{y \max}$	$c_y$					
[N]	[mm]	[N/mm]	[N]	[mm]	[N/mm]	[N]	[mm]	[N/mm]					
550	3	180	-	-	-	-	-	-	with	5718 817	45 NR	49047037	○
1000	3	330	-	-	-	-	-	-	with	5718 817	60 NR	49047038	○
1350	3	450	-	-	-	-	-	-	with	5718 817	70 NR	49047039	○

● Available from stock ○ On request: Tool is available, delivery at short notice

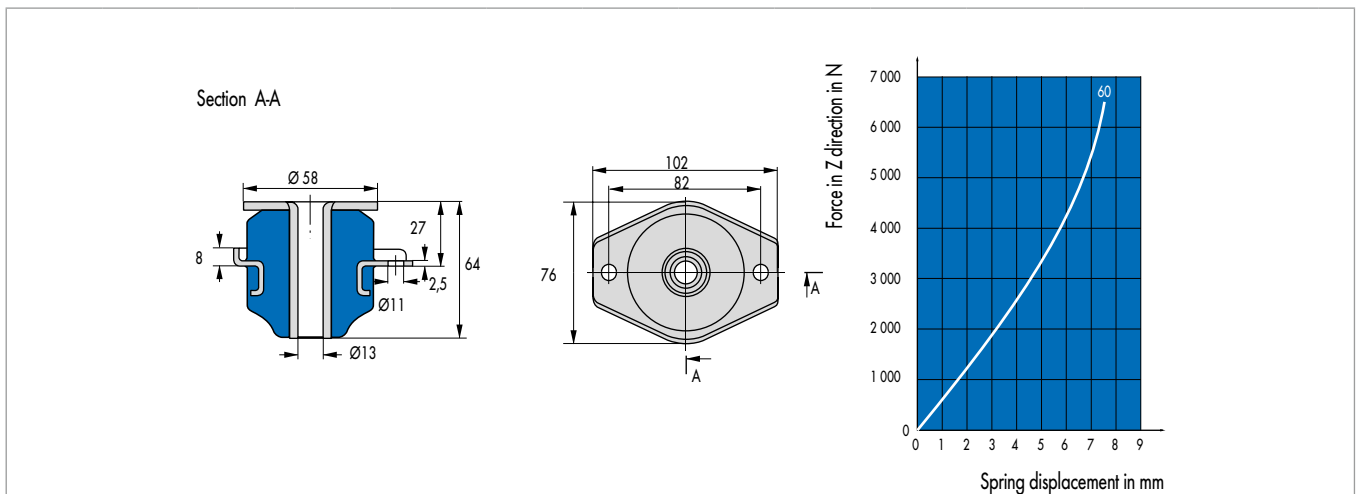

Fig. 28 Conical Mount 058 18 001

Nominal maxima		Stiffness	Nominal maxima		Stiffness	Nominal maxima		Stiffness	Window	Product No.	Material	Article No.	
Axial			Radial			Radial							
$F_{z \max}$	$s_{z \max}$	$c_z$	$F_{x \max}$	$s_{x \max}$	$c_x$	$F_{y \max}$	$s_{y \max}$	$c_y$					
[N]	[mm]	[N/mm]	[N]	[mm]	[N/mm]	[N]	[mm]	[N/mm]					
3000	7	300	200	1	200	200	1	200	without	5818 001	45 NR 11	91928	●
5500	7	620	330	1	330	330	1	330	without	5818 001	60 NR 11	90827	●
8200	7	900	500	1	500	500	1	500	without	5818 001	70 NR 11	92539	●

● Available from stock ○ On request: Tool is available, delivery at short notice

Elastomer Dampers

## V Mount

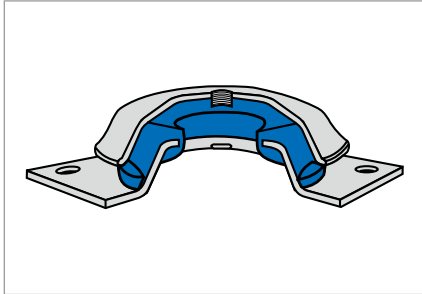

Fig. 1 V Mount

### Product description

V mounts are ideal for a multiplicity of applications in vibration control and structure-borne sound insulation.

### Product advantages

- Chrome-free galvanisation for optimum corrosion protection
- Easy fitting
- Maintenance-free
- Good insulation even at low interference frequencies
- RoHS-compliant.

### Application

The range of possible applications for V mounts includes internal combustion engines, electric motors, pumps, compressors and tool machines. V mounts are also used for maritime engineering. There are versions with type approval from Lloyds Register of Shipping available.

### Material

Standard material	Hardness
Natural rubber	40, 45, 50, 60, 65, 70 Shore A

### Operating conditions

<b>Axial forces in Z direction</b>	500 N ... 32000 N	Maximum permissible force
<b>Max. temperature</b>	up to 60 °C, transient up to +80 °C	
<b>Min. temperature</b>	up to -45 °C	

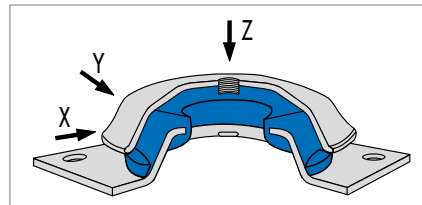

Fig. 2 Primary load directions

V mounts feature a robust compressive-deflection stop in the vertical direction (Z direction). The same high stiffness in both horizontal directions (X,Y) prevents a "floating", i.e. a lateral deflection of the vibration-insulated driven machinery, the machine or the engine. Versions with built-in tensile stops are also offered which limit the limit rebound in (-Z) direction. All V mounts are limited in their radial spring displacement at the same time. The bell-shaped designed top section of the mount protects against too strong a compressive deflection and dripping media (e.g. oil). When subjected to extreme overload a positive lock forms between the top and bottom section of the mount. The progressive spring characteristic and a thin rubber layer on the stop collar of the bottom section prevents a hard metal impact. The primary load direction (+Z) is perpendicular to the planes of attachment centred to the cap.

### Design notes

V mounts comprise a flat, cylindrical metal cap with threaded insert and a base plate with rectangular flange and through-holes. Both metal parts are aligned parallel on top of each other and joined with a vulcanised elastomer insert.

### Fitting & installation

- V mounts are designed to be secured by means of threaded fasteners
- Individual components permit slight adjustment to allow for in-situ offset
- It is important to ensure that the mating faces of the frame and the mass carried by the mount are flat and smooth
- Position the mount relative to the static load in such a way that the cap and the flange are preloaded relative to each other.

**Article list V Mount**

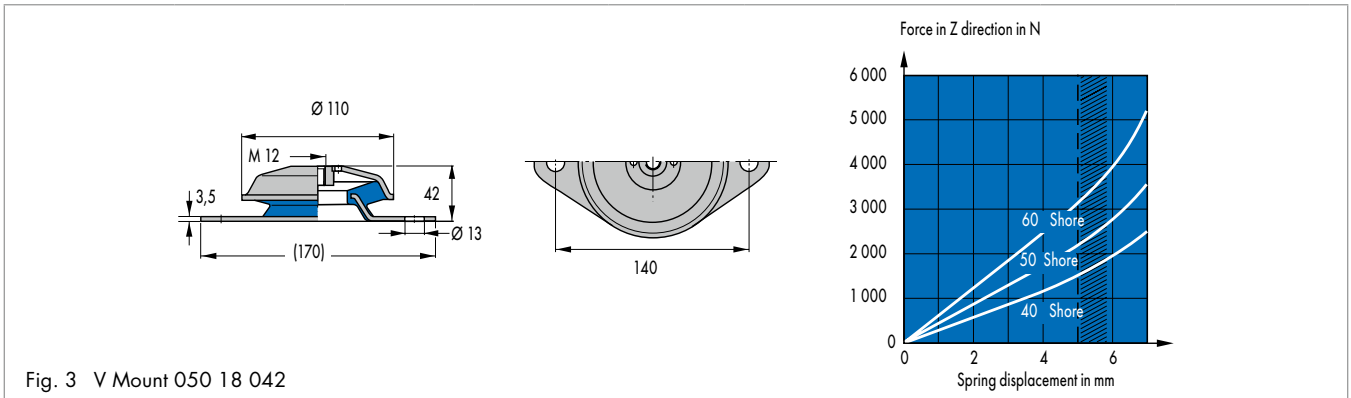

Fig. 3 V Mount 050 18 042

Nominal maxima			Stiffness		Product No.	Material	Stop	Article No.	
Axial		$c_z$	Radial						
$F_z \text{ max}$	$s_z \text{ max}$		$c_{x, y}$ ( $s_z=0$ )	$c_{x, y}$ ( $s_z=4$ )					
[N]	[mm]	[N/mm]	[N/mm]	[N/mm]					
2000	5	400	310	380	5018 042	40 NR 11	without	96517	•
2700	5	540	450	560	5018 042	50 NR 11	without	96518	•
4300	5	860	660	820	5018 042	60 NR 11	without	91131	•

• Available from stock    ○ On request: Tool is available, delivery at short notice

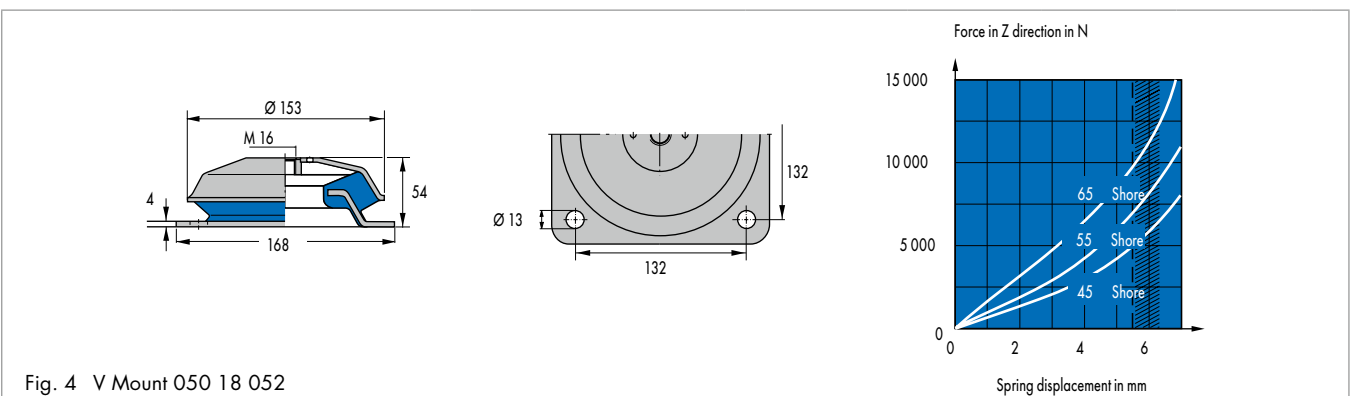

Fig. 4 V Mount 050 18 052

Nominal maxima			Stiffness		Product No.	Material	Stop	Article No.	
Axial		$c_z$	Radial						
$F_z \text{ max}$	$s_z \text{ max}$		$c_{x, y}$ ( $s_z=0$ )	$c_{x, y}$ ( $s_z=4$ )					
[N]	[mm]	[N/mm]	[N/mm]	[N/mm]					
5500	5	1100	590	770	5018 052	45 NR 11	without	96526	•
7700	5	1540	850	1100	5018 052	55 NR 11	without	96527	•
12200	5	2440	1200	1550	5018 052	65 NR 11	without	96528	•

• Available from stock    ○ On request: Tool is available, delivery at short notice

Elastomer Dampers

**Article list V Mount**

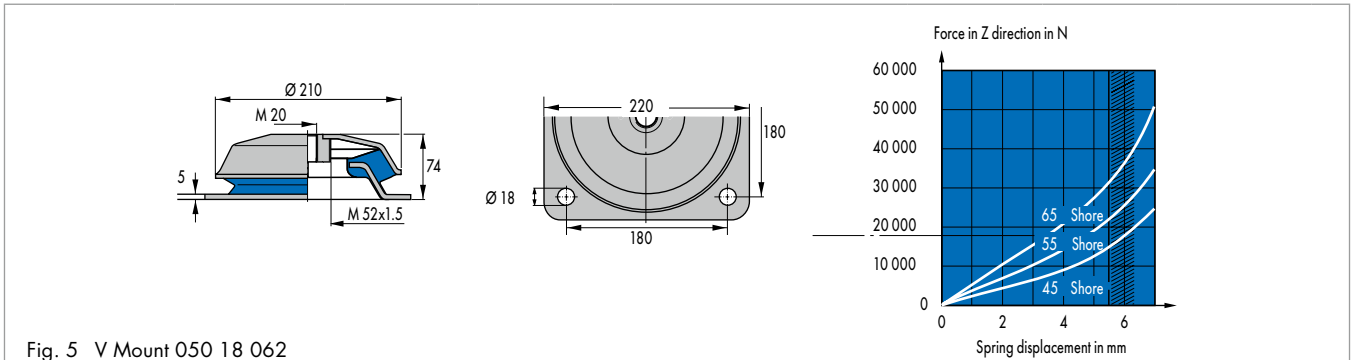

Fig. 5 V Mount 050 18 062

Nominal maxima		Stiffness			Product No.	Material	Stop	Article No.	
Axial		Radial							
$F_z \text{ max}$	$s_z \text{ max}$	$c_z$	$c_{x, y}$	$c_{x, y}$					
[N]	[mm]		[N/mm]	( $s_z=0$ )					
13200	5	2640	1800	2250	5018 062	45 NR 11	without	96537	•
20900	5	6180	2700	3300	5018 062	55 NR 11	without	96536	•
32000	5	6400	3900	4800	5018 062	65 NR 11	without	96535	•

• Available from stock    ○ On request: Tool is available, delivery at short notice

**Article list V Mount with stop**

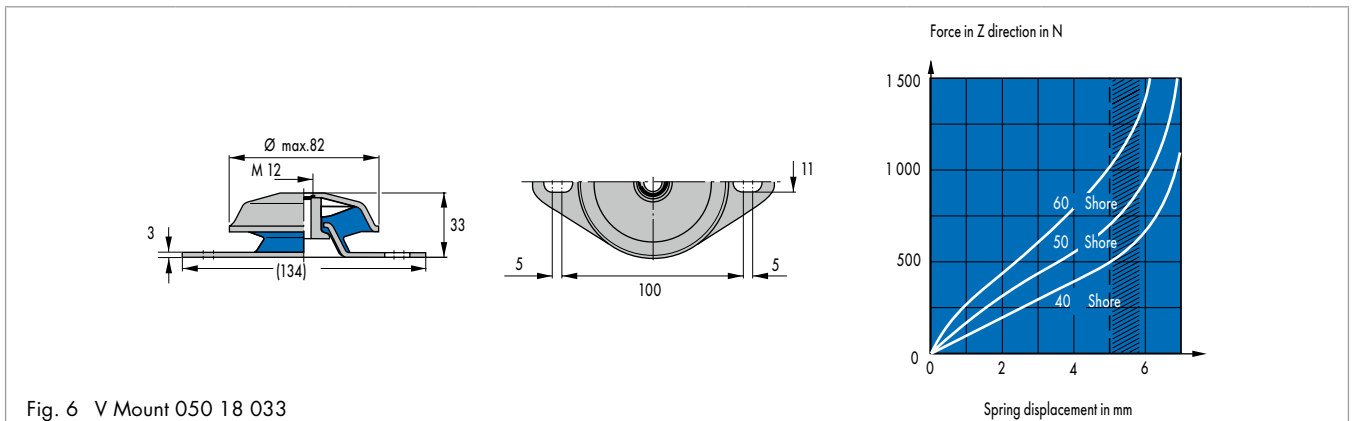

Fig. 6 V Mount 050 18 033

Nominal maxima		Stiffness			Product No.	Material	Stop	Article No.	
Axial		Radial							
$F_z \text{ max}$	$s_z \text{ max}$	$c_z$	$c_{x, y}$	$c_{x, y}$					
[N]	[mm]		[N/mm]	( $s_z=0$ )					
500	5	100	140	180	5018 033	40 NR 11	with	96538	•
700	5	140	200	250	5018 033	50 NR 11	with	96511	•
1000	5	200	280	360	5018 033	60 NR 11	with	96513	•

• Available from stock    ○ On request: Tool is available, delivery at short notice

Elastomer Dampers

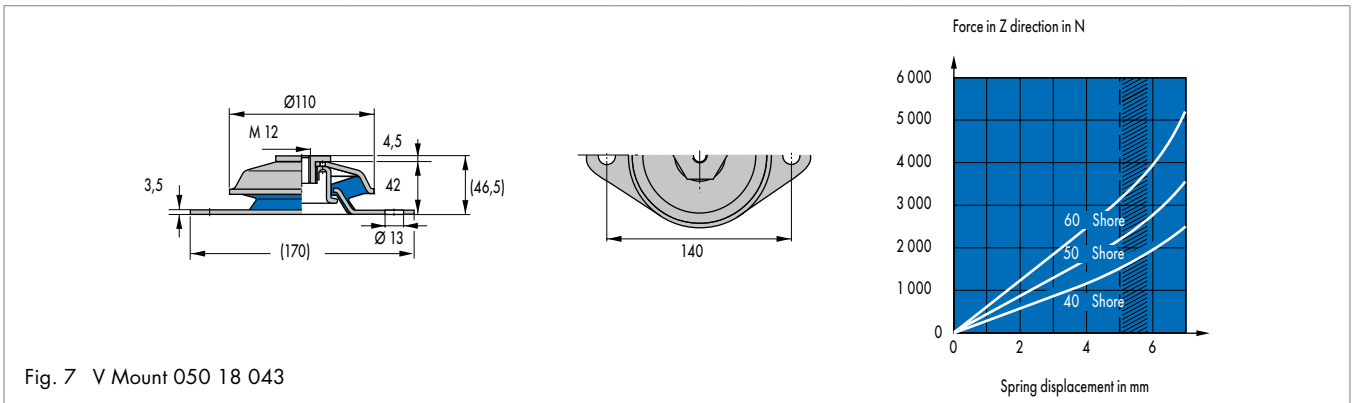

Fig. 7 V Mount 050 18 043

Nominal maxima			Stiffness		Product No.	Material	Stop	Article No.	
Axial		$c_z$	Radial						
$F_{z \max}$	$s_{z \max}$		$c_{x, y}$ ( $s_z=0$ )	$c_{x, y}$ ( $s_z=4$ )					
[N]	[mm]	[N/mm]	[N/mm]	[N/mm]					
1500	5	300	310	380	5018 043	40 NR 11	with	96520	•
2600	5	520	450	560	5018 043	50 NR 11	with	596521	•
4300	5	860	660	820	5018 043	60 NR 11	with	96522	•

● Available from stock   ○ On request: Tool is available, delivery at short notice

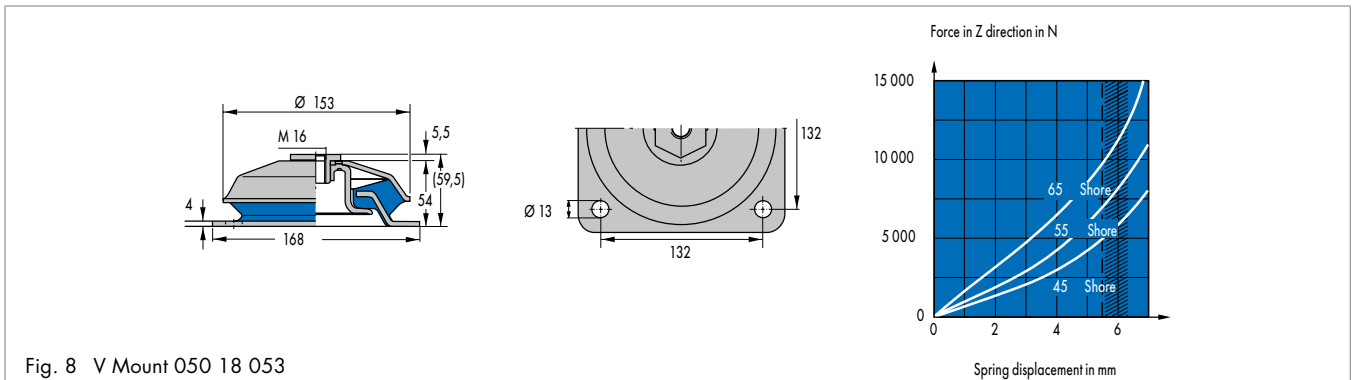

Fig. 8 V Mount 050 18 053

Nominal maxima			Stiffness		Product No.	Material	Stop	Article No.	
Axial		$c_z$	Radial						
$F_{z \max}$	$s_{z \max}$		$c_{x, y}$ ( $s_z=0$ )	$c_{x, y}$ ( $s_z=4$ )					
[N]	[mm]	[N/mm]	[N/mm]	[N/mm]					
5500	5	1100	590	770	5018 053	45 NR 11	with	96529	•
7700	5	1540	850	1100	5018 053	55 NR 11	with	96530	•
12200	5	2440	1200	1550	5018 053	65 NR 11	with	96531	•

● Available from stock   ○ On request: Tool is available, delivery at short notice

Article list V Mount with stop

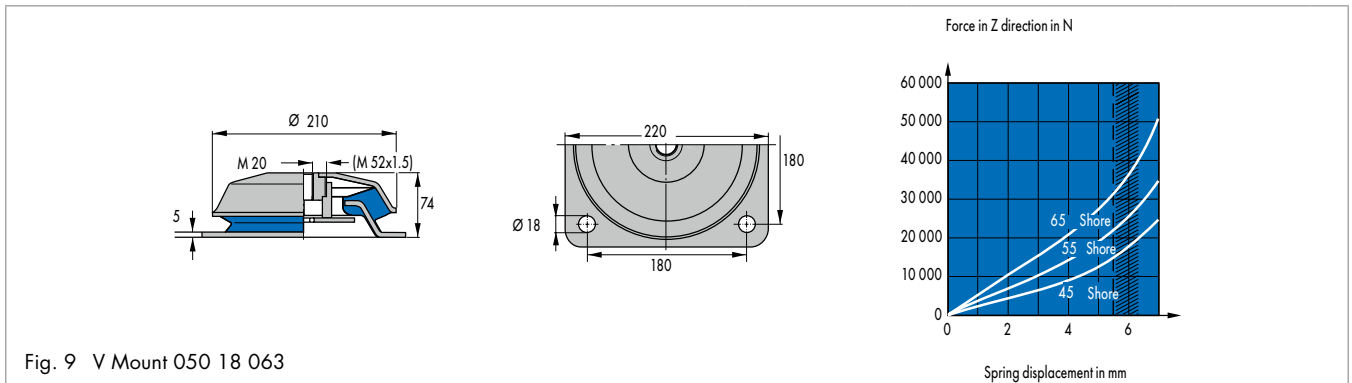

Fig. 9 V Mount 050 18 063

Nominal maxima		Stiffness			Product No.	Material	Stop	Cat. No.	
Axial		Radial							
$F_z \text{ max}$	$s_z \text{ max}$	$c_z$	$c_{x, y}$ ( $s_z=0$ )	$c_{x, y}$ ( $s_z=4$ )					
[N]	[mm]	[N/mm]	[N/mm]	[N/mm]					
13200	5	2640	1800	2250	5018 063	45 NR 11	with	49040497	○
30900	5	6180	2700	3300	5018 063	55 NR 11	with	49040498	○
32000	5	6400	3900	4800	5018 063	65 NR 11	with	49040499	○

● Available from stock ○ On request: Tool is available, delivery at short notice

Elastomer Dampers

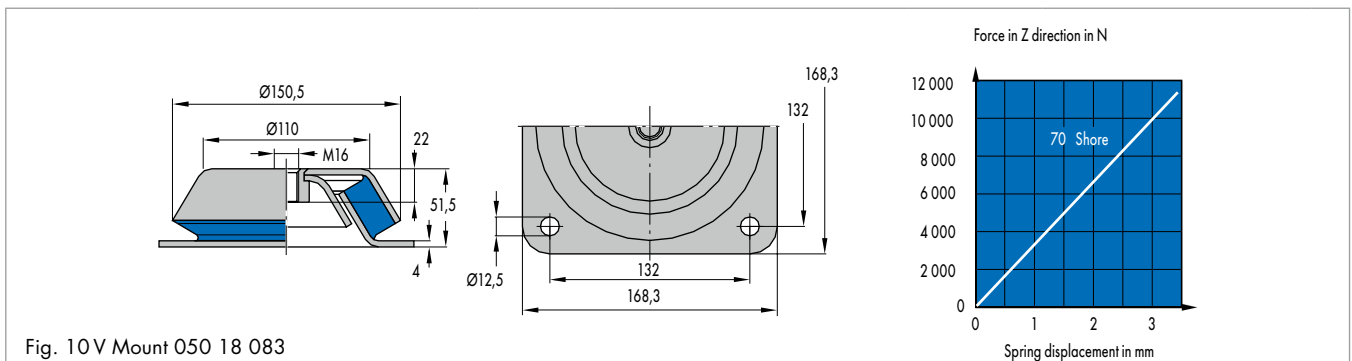

Fig. 10 V Mount 050 18 083

Nominal maxima		Stiffness			Product No.	Material	Stop	Cat. No.	
Axial		Radial							
$F_z \text{ max}$	$s_z \text{ max}$	$c_z$	$c_{x, y}$ ( $s_z=0$ )	$c_{x, y}$ ( $s_z=4$ )					
[N]	[mm]	[N/mm]	[N/mm]	[N/mm]					
10000	3	3330	2400	3800	5018 083	70 NR	with	49040500	○

● Available from stock ○ On request: Tool is available, delivery at short notice



# MO Mount

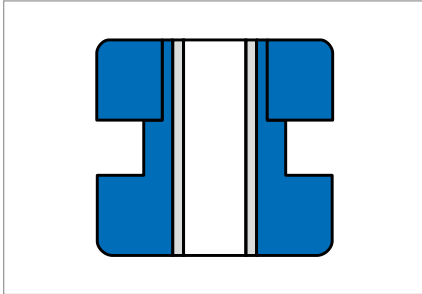

Fig. 1 MO Mount Type I

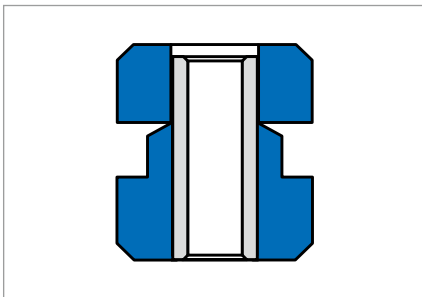

Fig. 2 MO Mount Type II

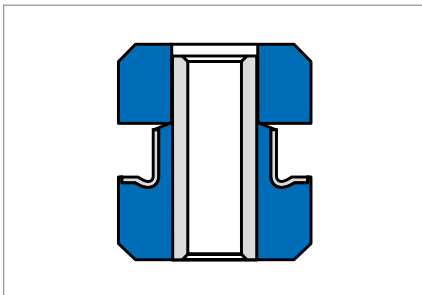

Fig. 3 MO Mount Type III

### Product description

MO mounts are suitable for use as resilient connecting elements.

### Product advantages

- Dependable limitation of radial deflection
- Compact
- Good insulating capability in the longitudinal direction
- RoHS-compliant.

### Application

The range of possible applications for MO mounts is wide, extending from applications with driven machinery, PTOs and radiators up to small cabs for vehicles, and also including attachments for exhaust-air ducts and exhaust pipes in maritime engineering.

### Material

Standard material	Hardness
Chlorine-butadiene rubber	42, 45, 50, 55, 60, 64, 75 Shore A

### Operating conditions

Radial forces	1000 N ... 2800 N	Maximum permissible force
Axial forces	1800 N ... 2400 N	Maximum permissible force
Max. temperature	+100 °C, transient +130 °C	
Min. temperature	-30 °C	

MO mounts feature equal stiffness in the horizontal directions (X,Y). These mounts have a greater flexibility in the Z direction which leads to a correspondingly higher isolation. The limitation of the spring displacements in the radial direction generally appear more than in the axial direction. The longitudinal axis is recommended as the primary load direction.

### Design notes

The MO mount with central borehole comprises an elastomer body and a vulcanised elastomer metal part. These parts attached to each other create an annular clamping groove. This mount configuration is expandable through layers or spatially corresponding limiter components for the axial spring displacement which leads to a progressive spring characteristic curve and serves as tear-off protection at the same time.

### Fitting & installation

- MO mounts are designed to accommodate a threaded fastener inserted through the central borehole
- Individual components permit slight adjustment to allow for in-situ offset
- Combine the mount with a tubular spacer if tightening torques are high
- Depending on the quality of the material selected, threaded-fasteners of at least one strength class higher can be used
- Select a tubular spacer with an outside diameter allowing slight play for the inside diameter  $d_1$  of the MO mount
- Select the through-hole of the tubular spacer to accommodate the securing screw according to DIN EN 20273
- The surfaces for force transfer to the threaded fastener by the elastomer part should be large and flat
- Position MO mounts such that the rubber-metal part bolts directly to the component to be insulated
- Install the elastomer-only part with a washer (see the section on washers and centering washers for details of the washer)
- Make sure that the edges of bore  $S_D$  are chamfered, or preferably radiused, at both ends
- MO mounts with steel reinforcement (Type 3) require this radiusing only at the rubber-only end.

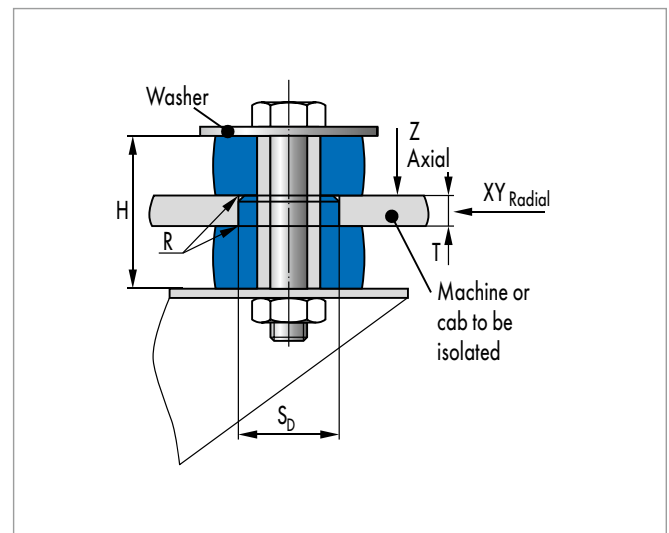
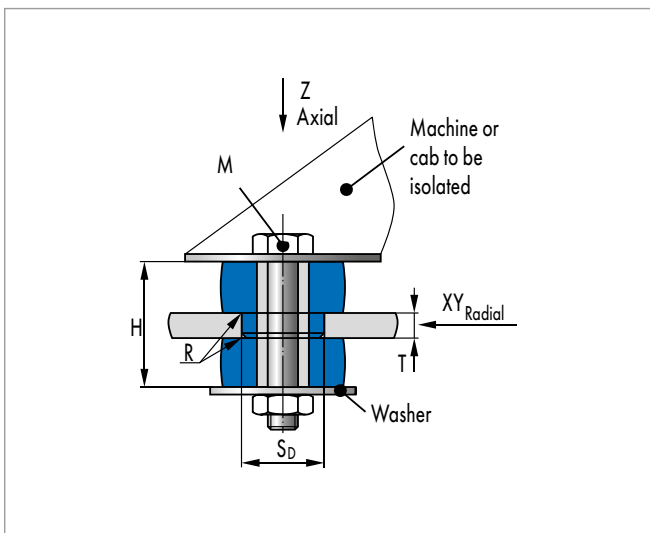

Fig. 4 Fitting & installation instructions: MO Mount with load directions

Article list

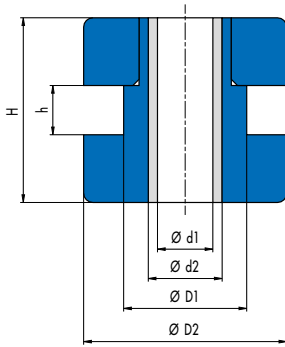

Fig. 5 MO Mount Type I

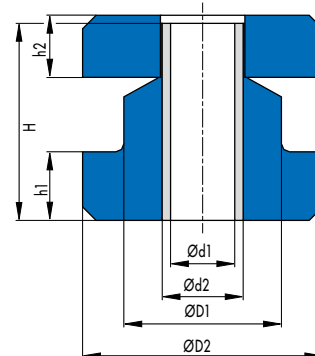

Fig. 6 MO Mount Type II

Nominal maxima			Stiffness	Nominal maxima			Stiffness	Main dimensions						Frame	
Axial pressure			Radial shear			Pipe		Thickness		Installation Ø	Outside Ø	Tube length	Borehole Ø	Thickness	
F <sub>z max</sub>	s <sub>z max</sub>	c <sub>z max</sub>	F <sub>x, y max</sub>	s <sub>x, y max</sub>	c <sub>x, y max</sub>	d <sub>1</sub>	d <sub>2</sub>	h <sub>1</sub>	h <sub>2</sub>	D <sub>1</sub>	D <sub>2</sub>	H	S <sub>D</sub> ±0,1	T	
[N]	[mm]	[N/mm]	[N]	[mm]	[N/mm]	[mm]	[mm]	[mm]	[mm]	[mm]	[mm]	[mm]	[mm]	[mm]	
420	1,5	280	540	1,0	540	9,0	12,0	11,0	11,0	20,0	33,0	30,0	20,5	9	
1800	1,5	1200	2300	1,0	2300	9,0	12,0	11,0	11,0	20,0	33,0	30,0	20,5	9	
640	3,3	190	240	1,2	200	9,0	21,3	20,5	19,5	33,0	48,0	50,0	33,4	13	
840	3,1	270	300	4,2	70	9,0	21,3	20,5	19,5	33,0	48,0	50,0	33,4	13	
910	2,2	410	340	2,2	150	9,0	21,3	20,5	19,5	33,0	48,0	50,0	33,4	13	
2970	2,7	1100	1570	3,8	410	9,0	21,3	20,5	19,5	33,0	48,0	50,0	33,4	13	
620	3,0	210	380	1,0	380	13,5	20,7	20,5	19,5	33,0	48,0	50,0	33,5	12	
1650	3,0	550	1000	1,0	1000	13,5	20,7	20,5	19,5	33,0	48,0	50,0	33,5	12	
900	3,0	300	1100	1,0	1100	13,5	20,7	20,5	19,5	31,2	48,0	50,0	31,5	13	
1600	3,0	530	1900	1,0	1900	13,5	20,7	20,5	19,5	31,2	48,0	50,0	31,5	13	
2400	3,0	800	2800	1,0	2800	13,5	20,7	20,5	19,5	31,2	48,0	50,0	31,5	13	
3900	3,0	1300	4500	1,0	4500	13,5	20,7	20,5	19,5	31,2	48,0	50,0	31,5	13	
2100	3,0	700	1400	1,0	1400	16,7	26,0	22,9	22,9	40,1	64,8	61,7	40,5	20	
3000	3,0	1000	200	1,0	200	16,7	26,0	22,9	22,9	40,1	64,8	61,7	40,5	20	
1330	2,3	580	560	1,1	510	23,8	31,3	25,4	23,0	58,4	89,0	73,0	58,8	29	
1890	2,8	680	1140	2,3	500	23,8	31,3	25,4	23,0	58,4	89,0	73,0	58,8	29	
2940	3,7	790	1660	1,9	870	23,8	31,3	25,4	23,0	58,4	89,0	73,0	58,8	29	
5700	1,5	3800	2520	1,6	1580	23,8	31,3	25,4	23,0	58,4	89,0	73,0	58,8	29	

● Available from stock    ○ On request: Tool is available, delivery at short notice

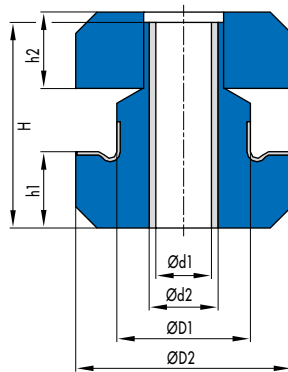

Fig. 7 MO Mount Type III

	max. screw strength class (without sleeve)	max. tightening torque	Product No.	Material	Type	Corrosion protection	Article No.	
	M	$M_{sp}$						
		[Nm]						
	M 6 6.8/M 8 5.6	7,5 / 11,0	3918 753	40 CR	I	phosphated	49031354	•
	M 6 6.8/M 8 5.6	7,5 / 11,0	3918 753	75 CR	I	phosphated	511453	•
	M 8 12.9	40,0	3918 765	45 CR 057	II	Fe//Zn8Znph/r/3	49029937	•
	M 8 12.9	40,0	3918 765	50 CR 057	II	Fe//Zn8Znph/r/3	49038236	○
	M 8 12.9	40,0	3918 765	60 CR 057	II	Fe//Zn8Znph/r/3	49038235	○
	M 8 12.9	40,0	3918 765	75 CR 057	II	Fe//Zn8Znph/r/3	49038234	○
	M10 8.8/M12 5.6	47,0/39,0	3918 754	42 CR	II	phosphated	49011344	•
	M10 8.8/M12 5.6	47,0/39,0	3918 754	64 CR	II	phosphated	511454	•
	M10 8.8/M12 5.6	47,0/39,0	3918 755	42 CR	III	phosphated	49012351	○
	M10 8.8/M12 5.6	47,0/39,0	3918 755	55 CR	III	phosphated	2129379	•
	M10 8.8/M12 5.6	47,0/39,0	3918 755	64 CR	III	phosphated	511452	•
	M10 8.8/M12 5.6	47,0/39,0	3918 755	75 CR	III	phosphated	49003069	•
	M12 5.6	39,0	3918 768	45 CR	II	phosphated	49038161	○
	M12 5.6	39,0	3918 768	60 CR	II	phosphated	49038160	○
	M16 5.8/M20 4.6	126,0/147,0	3918 766 HD	45 CR 057	II	Fe//Zn8Znph/r/3	49033624	○
	M16 5.8/M20 4.6	126,0/147,0	3918 766 HD	50 CR 057	II	Fe//Zn8Znph/r/3	49036771	○
	M16 5.8/M20 4.6	126,0/147,0	3918 766 HD	60 CR 057	II	Fe//Zn8Znph/r/3	49036770	○
	M16 5.8/M20 4.6	126,0/147,0	3918 766 HD	75 CR 057	II	Fe//Zn8Znph/r/3	49036769	○

## Machine Mount

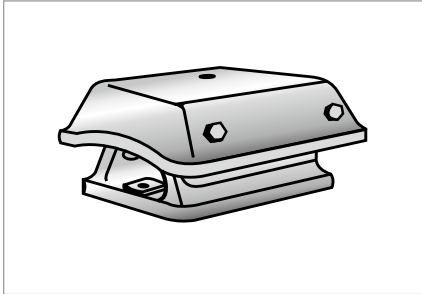

Fig. 1 Machine Mount

### Product description

The special shape of the machine mount protects the built-in flat mount against mechanical damage and oil attack.

### Product advantages

- Elastomer spring elements are replaceable and the metal connecting components are reusable
- Spring elements are protected against random damage and direct oil splashes
- Reduced settling in the Z direction
- RoHS-compliant.

### Application

Machine mounts are particularly suitable for mounting heavy machines, compressors, engines, etc. They enable machine- and unit-generated vibrations introduced into the foundation or the enclosing building to be reduced by a significant margin.

### Material

Standard material	Hardness
Natural rubber	45, 50, 55, 60, 70 Shore A

### Operating conditions

<b>Axial forces in Z direction</b>	1400 N ... 16000 N	Maximum permissible force
<b>Max. temperature</b>	+60 °C, transient +80 °C	
<b>Min. temperature</b>	-45 °C	

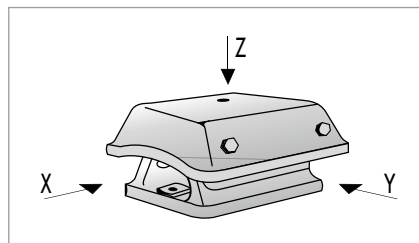

Fig. 2 Primary load directions

The combined compression and shear loading of the flat mounts fitted provides a long service life and good vibration insulation, even at lower interference frequencies (i.e. lower rotational speed). The mount is easily attached to the foundation and the machine using the standard boreholes and threads. Anchoring to the foundation and the machine permits the application of compressive loads (Z direction) to the mount as well as shear loads (X & Y direction). The primary load direction is perpendicular to the planes of attachment, centred to the cap.

### Design notes

The machine mount comprises a rectangular cap and two metal parts with equally angled side faces and flange. Flat mounts are screwed in between the two stacked metal parts. Both metal parts are provided with through-holes or threaded holes.

### Fitting & installation

- Machine mounts are designed to be anchored by threaded fasteners
- Individual components permit slight adjustment to allow for in-situ offset
- It is important to ensure that the mating faces of the frame and the mass carried by the mount are flat and smooth
- Position the mount relative to the static load in such a way that the cap and the flange are preloaded relative to each other.

Article list

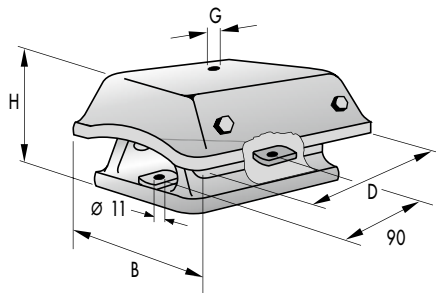

Fig. 3 Machine Mount 050 18 001

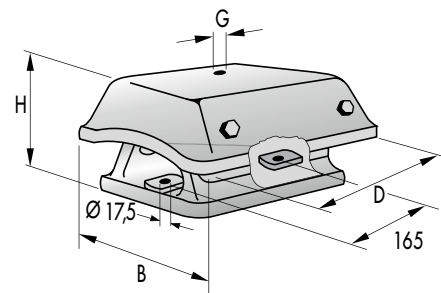

Fig. 4 Machine Mount 050 18 002, 050 18 004

Nominal maxima		Stiffness	Length	Width	Height	Threads	Product No.	Material	Type	Article No.	
$F_{z \max}$	$s_{z \max}$	$c_z$	D	B	H	G					
[N]	[mm]	[N/mm]	[mm]	[mm]	[mm]						
1400	5,8	240	121	127	72	M12	5018 001	45 NR 11	A3	96808	•
1400	5,8	240	121	127	72	M16	5018 001	45 NR 11	A3	49047069	•
1800	5,8	310	121	127	72	M12	5018 001	50 NR 11	A2	96806	•
1800	5,8	310	121	127	72	M16	5018 001	50 NR 11	A2	49041129	○
3000	5,8	520	121	127	72	M12	5018 001	60 NR 11	A1	96809	•
3000	5,8	520	121	127	72	M16	5018 001	60 NR 11	A1	49047070	•
5200	5,8	900	121	127	72	M12	5018 001	70 NR 11	A0	96807	•
5200	5,8	900	121	127	72	M16	5018 001	70 NR 11	A0	49047071	•
6500	6,0	1080	228	203	110	M16	5018 002	45 NR 11	B3	96802	•
9500	6,0	1580	228	203	110	M16	5018 002	55 NR 11	B2	96805	•
12500	6,0	2080	228	203	110	M16	5018 002	60 NR 11	B1	96804	•
16000	6,0	2670	228	203	110	M16	5018 002	70 NR 11	B0	96803	•
5000	11,0	450	228	203	125	M16	5018 004	45 NR 11	HD3	596744	•
8500	11,0	770	228	203	125	M16	5018 004	55 NR 11	HD2	96800	•
9500	11,0	860	228	203	125	M16	5018 004	60 NR 11	HD1	96920	•
12500	11,0	1140	228	203	125	M16	5018 004	70 NR 11	HD0	96801	•

• Available from stock    ○ On request: Tool is available, delivery at short notice

# Flat Mount

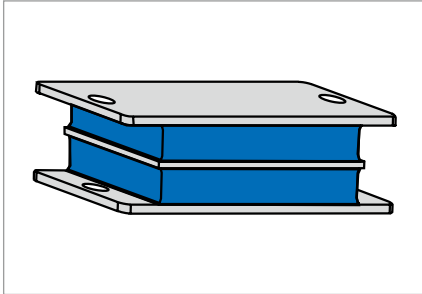

Fig. 1 Flat Mount

## Product description

Flat mounts are mount configurations for custom applications.

## Product advantages

- Easily integrated into assemblies
- Easily installed
- Spring characteristics can be widely adapted to the construction
- RoHS-compliant.

## Application

Used as mounts for machines, engines or subassemblies in mechanical-engineering and automotive applications.

## Material

Standard material	Hardness
Natural rubber	45, 50, 55, 60, 65, 70 Shore A

## Operating conditions

Shear forces X,Y direction	440 N ... 7500 N	Maximum permissible force
Compressive forces in Z direction	1200 N ... 98000 N	Maximum permissible force
Max. temperature	+60 °C, transient +80 °C	
Min. temperature	-45 °C	

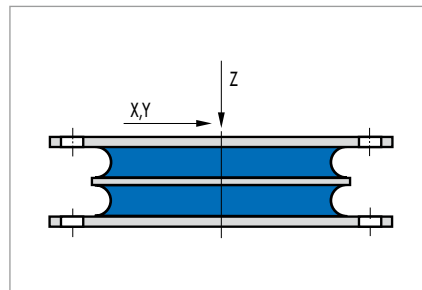

Fig. 2 Primary load directions

Depending on the installation conditions or required degree of vibration insulation, compressive loads (Z direction), shear loads (X, Y direction) or combined compressive/shear loads (mount tilted by a specific angle) can be applied to flat mounts. The mounts achieve an optimal utilisation and thus also the highest dynamic load with a compressive/shear loading. The loading is dependent on the surface area of the rubber, shape, thickness of the pad and hardness of the rubber. The static loading and the dynamic forces and deflection must be taken into account for continuous use. Flat mounts have different stiffness in the shear direction (X,Y) and compressive direction (Z) in dependence on the width, length and thickness and their total number in the mount component. The effective stiffness of the mounts can be varied by turning of the mount to the static load. The primary load direction can be absorbed perpendicular to or at an angle to the attachment levels.

## Design notes

Flat mounts consist of parallel metal plates paralleled one on top of the other and separated by vulcanised elastomer pads.

## Fitting & installation

- Flat mounts are designed to be secured by means of threaded fasteners
- Individual components permit slight adjustment to allow for in-situ offset
- It is important to ensure that the mating faces of the frame and the mass carried by the mount are flat and smooth
- It is also important to ensure full-surface contact between the outer metal plates and the frame and the mass carried by the mounts
- Position the mount relative to the static load in such a way that the cap and the flange are preloaded relative to each other.



Article list

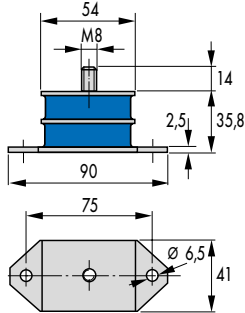

Fig. 3 Flat Mount 051 18 001

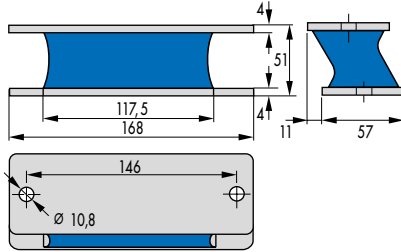

Fig. 4 Flat Mount 051 18 004

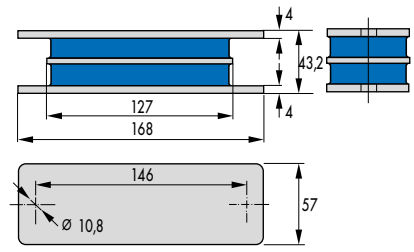

Fig. 5 Flat Mount 051 18 002

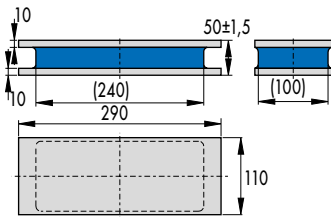

Fig. 6 Flat Mount 051 18 719

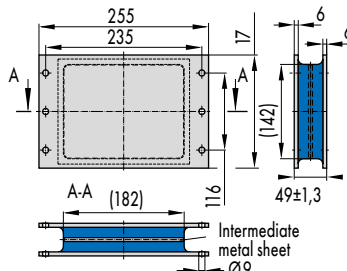

Fig. 7 Flat Mount 051 18 720

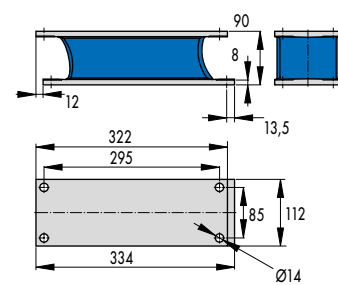

Fig. 8 Flat Mount 051 18 723

Nominal maxima			Nominal maxima			Width	Height	Length	Product No.	Material	Article No.	
Pressure			Shear									
$F_z$ max	$s_z$ max	$c_z$ pres- sure	$F_{x,y}$ max	$s_{x,y}$ max	$c_{x,y}$ shear	B	H	L				
[N]	[mm]	[N/mm]	[N]	[mm]	[N/mm]	[mm]	[mm]	[mm]				
1200	2,4	500	440	11	40	41	35,8	90	5118 001	45 NR 11	96796	•
1500	2,4	630	500	10	50	41	35,8	90	5118 001	50 NR 11	96797	•
2300	2,4	960	600	8	80	41	35,8	90	5118 001	60 NR 11	96798	•
3000	2,4	1250	800	7	110	41	35,8	90	5118 001	70 NR 11	96745	•
7400	2,7	2740	1700	13	130	57	43,2	168	5118 002	45 NR 11	96791	•
9000	2,7	3330	2200	11	200	57	43,2	168	5118 002	55 NR 11	96793	•
15100	2,7	5590	2400	10	240	57	43,2	168	5118 002	65 NR 11	96792	•
18900	2,7	7000	3000	8	380	57	43,2	168	5118 002	70 NR 11	96794	•
1400	3,5	400	1100	15	70	57	51,0	168	5118 004	45 NR 11	96787	•
2800	3,5	800	1900	15	130	57	51,0	168	5118 004	55 NR 11	96788	•
3060	3,5	870	2000	13	150	57	51,0	168	5118 004	60 NR 11	96789	•
4700	3,5	1340	2200	11	200	57	51,0	168	5118 004	70 NR 11	96790	•
25000	2,0	12500	5800	12	480	110	50,0	290	5118 719	60 NR 11	49002463	○
41000	2,0	20500	4000	8	500	170	49,0	255	5118 720	45 NR 11	49002649	○
98000	2,0	49000	7500	8	940	170	49,0	255	5118 720	60 NR 11	49002650	○
8000	3,0	2700	5500	12	460	112	90,0	322	5118723	60 NR 11	49038296	○

• Available from stock    ○ On request: Tool is available, delivery at short notice

# Rails

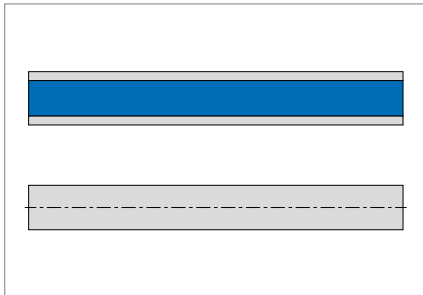

Fig. 1 Rails

## Product description

Rails are often used when space is at a premium or if loads are too high to permit the use of buffers.

## Product advantages

- Mount can be customised
- Rails have the flexibility to be adapted to the load
- Universal
- RoHS-compliant.

## Application

Rails from Simrit are suitable for mounting the most heavy machines, plants, units and foundations. They are suitable for a wide range of possible application for mounting ships engines, large stationary engines, heavy-duty lathes, hoists for lifts as well as vibratory machines of all kinds.

## Material

Standard material	Hardness
Natural rubber	57 Shore A

## Operating conditions

Length of rail in mm	25 ... 2000
----------------------	-------------

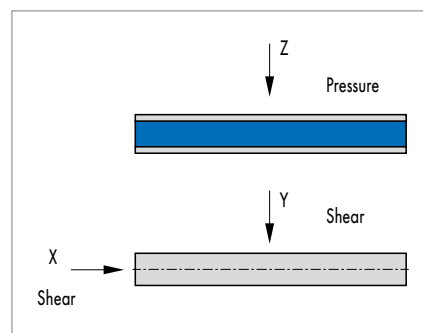

Fig. 2 Primary load directions

The rails are available in 2000 mm lengths. You must ensure that the length is not shorter than the section width. Approximately 10% of the rubber height "h" can be pressed together under static load.

## Design notes

The component consists of two metal parts separated by a vulcanised elastomer pad.

## Fitting & installation

- Rails can be drilled and chased on site to accommodate threaded fasteners
- Rails can also be installed without threaded fasteners if compressive-load deflection is significantly greater than maximum amplitude.

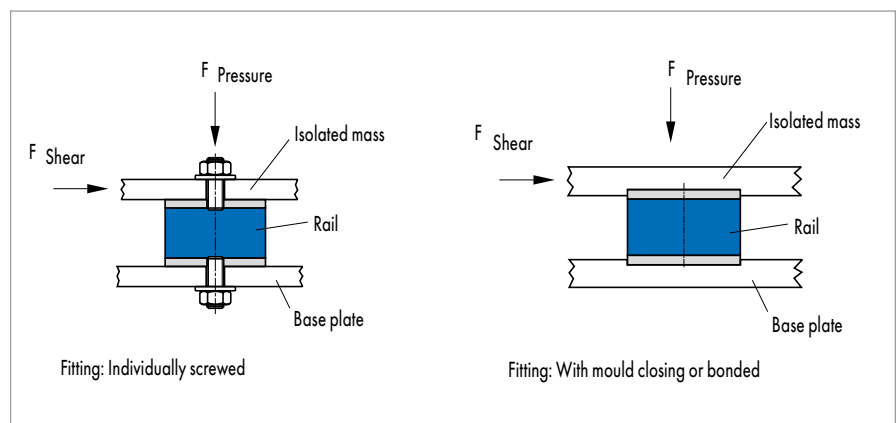

Fig. 3 Fitting & installation: rails with load directions

**Article list**

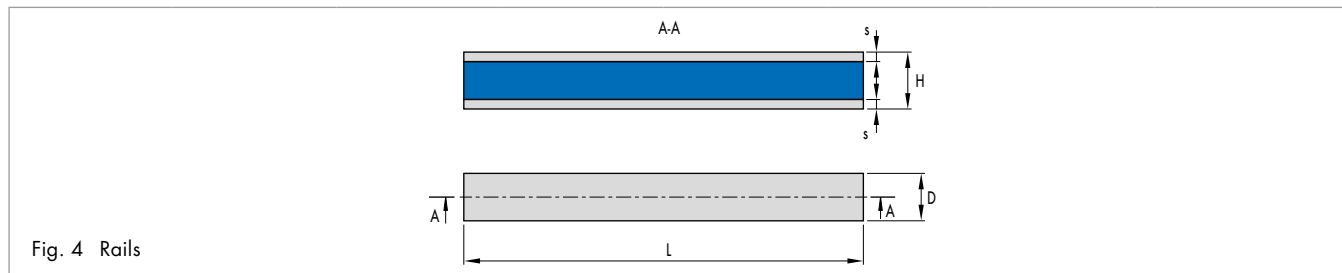

Fig. 4 Rails

Length	Width	Height	Sheet thickness	Tol.	Product No.	Material	Article No.	
L	D	H	S					
[mm]	[mm]	[mm]	[mm]			[±5 Shore A]		
2000	25	30	5	±0,2	05118 724	57 NR	49041337	○
2000	40	35	10	±0,2	05118 725	57 NR	49041338	○
2000	50	40	10	±0,2	05118 726	57 NR	49041339	○
2000	50	50	10	±0,2	05118 727	57 NR	49041340	○
2000	50	70	10	±0,2	05118 728	57 NR	49041341	○
2000	60	60	10	±0,2	05118 729	57 NR	49041372	○
2000	70	50	10	±0,2	05118 730	57 NR	49041373	○
2000	100	60	15	±0,2	05118 731	57 NR	49041374	○
2000	100	80	15	±0,2	05118 732	57 NR	49041375	○
2000	150	65	15	±0,2	05118 733	57 NR	49041376	○
2000	150	80	15	±0,2	05118 734	57 NR	49041377	○

● Available from stock    ○ On request: Tool is available, delivery at short notice

# Tapered Mount

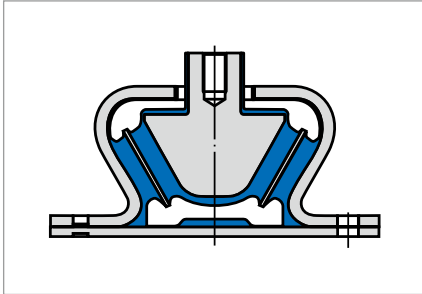

Fig. 1 Tapered Mount

## Material

Standard material	Hardness
Natural rubber NR 39	40, 42, 45, 50, 60 Shore A

## Operating conditions

Compressive forces in Z direction	1750 N ... 14000 N	Maximum permissible force
Max. temperature	+80 °C, transient +100 °C	
Min. temperature	-45 °C	

## Product description

Tapered mounts are used primarily to carry light, medium and heavy engines for mobile and stationary applications.

## Product advantages

- Robust
- Slight settling on compressive deflection in the Z direction by using special natural rubber
- Effective limitation of compressive and rebound deflection
- Limitation of horizontal spring displacement
- Narrow, ideal for mounting on steel sections
- RoHS-compliant.

## Application

Tapered mounts can be utilised for agricultural and construction machinery. They are also suited for mounting generators of ships' engines.

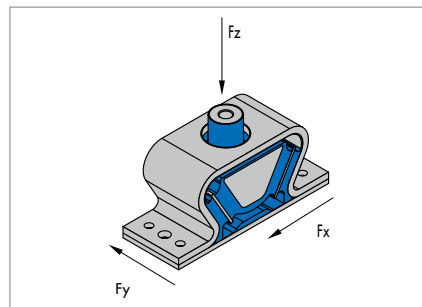

Fig. 2 Primary load directions

Tapered mounts have limiters for deflection in all spatial directions whereby the deflection in the Z direction is especially robust. In compressive-deflection direction Z, the mount also has a "soft" end stop. The stiffness depend primarily on the thickness, length, height and the wedge angle to the Z axis. Through the use of intermediate metal sheets, the Z stiffness, for example, is at least doubled for the same operating environment. The primary static load should be perpendicular to the planes of attachment.

## Design notes

The tapered mount comprises an outer omega-shaped bracket with flange and through-hole. An inner metal part with threaded hole partially plunges through a borehole of the bracket. Elastomer pads are vulcanised between both metal parts in Vee shape.

## Fitting & installation

- Tapered mounts are designed to be secured by means of threaded fasteners
- Avoid non-load-dependent offset of the inner metal part relative to the flange
- Individual components permit slight adjustment to allow for in-situ offset
- It is important to ensure that the mating faces of the frame and the mass carried by the mount are paralleled, flat and smooth.

**Article list**

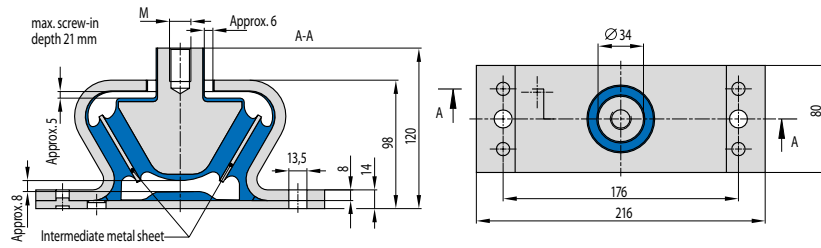

Fig. 3 Tapered Mounts 033 18 720, 033 18 730

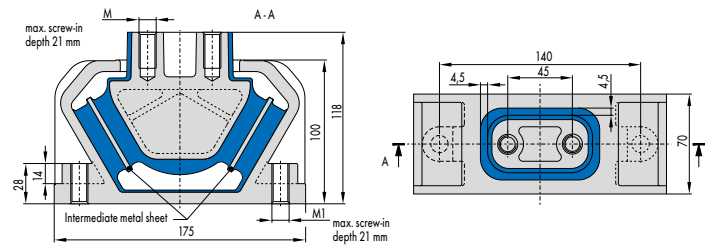

Fig. 4 Tapered Mounts 033 18 700, 033 18 701

Nominal maxima		Stiffness			Threads top	Threads base	Product No.	Material		Intermediate metal sheet	Article No.	
$F_z$ max	$s_z$ max	$c_z$	$c_x$	$c_y$	M	M1		Rubber	Metal			
[N]	[mm]	[N/mm]	[N/mm]	[N/mm]								
2200	5	440	1700	500	M12	M12	033 18 700	42 NR 39	aluminium	without	511470	○
3400	5	680	2600	770	M12	M12	033 18 700	50 NR 39	aluminium	without	2129315	○
5300	5	1060	4000	1200	M12	M12	033 18 700	60 NR 39	aluminium	without	2129317	○
5800	5	1160	4500	1300	M12	M12	033 18 701	45 NR 39	aluminium	with	2129378	○
8900	5	1780	6900	2000	M12	M12	033 18 701	50 NR 39	aluminium	with	2129321	○
14000	5	2800	10800	3200	M12	M12	033 18 701	60 NR 39	aluminium	with	2129323	○
4500	5	900	3200	185	M16		033 18 720	40 NR 39	steel	with	49025343	●
6000	5	1200	4800	280	M16		033 18 720	50 NR 39	steel	with	49025344	●
10000	5	2000	8000	465	M16		033 18 720	60 NR 39	steel	with	49025345	●
1750	5	350	700	100	M16		033 18 730	40 NR 39	steel	without	49025346	●
2920	5	580	1400	200	M16		033 18 730	50 NR 39	steel	without	49025347	●
4000	5	800	2400	330	M16		033 18 730	60 NR 39	steel	without	49025348	●

● Available from stock    ○ On request: Tool is available, delivery at short notice

## Double U-Shear Mount

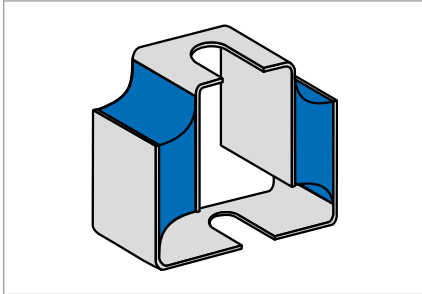

Fig. 1 Double U-Shear Mount

### Product description

Double U-shear mounts are especially suited for isolation tasks. These mounts have an especially simple design and a high ease of installation.

### Product advantages

- Good insulating capability in the Z direction
- Effective limitation of shock loads in the compressive-deflection direction
- Virtually no progression
- Linear characteristic
- RoHS-compliant.

### Application

Double U-shear mounts are used to mount instruments, units, pumps, compactors and compressors. They are equally suitable for the decoupling of exhaust-air ducts because of their ability to compensate for structure-borne sound and thermal expansion.

### Material

Standard material	Hardness
Natural rubber	45, 50, 60, 70 Shore A

### Operating conditions

Shear $F_z/F_y$	120 N ... 2000 N	Maximum permissible force
Max. temperature	+60 °C, transient +80 °C	
Min. temperature	-45 °C	

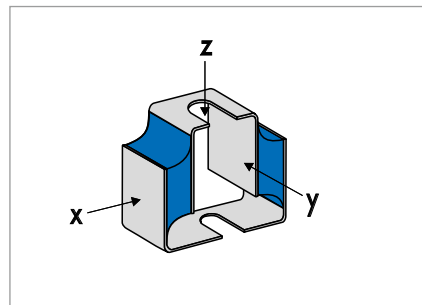

Fig. 2 Primary load directions

### Design notes

A mount of this type consists of two dovetailed U-shaped steel channel sections held together by elastomer pads.

They are designed so that the stiffness to resist shear increases in the order Y, Z, X. Depending on the type, they limit strong shock loads in the compressive-deflection direction (+Z). The effective stiffness can be adjusted by turning the mount on the static load (Z axis). Select the primary load direction +Z so that it is perpendicular to the planes of attachment.

### Fitting & installation

- Double U-shear mounts have threads to accommodate grooves.
- Avoid non-load-dependent offset of the U-shaped channel sections relative to each other
- Individual components permit slight adjustment to allow for in-situ planar or angular offset
- It is important to ensure full-surface contact between the mating faces of the U-shaped channel sections and the frame on the one hand and the supported mass on the other.

Article list



Fig. 3 Double U-Shear Mount 053 18 001, 053 18 002, 053 18 003 and 053 18 004

Nominal maxima		Stiffness	A	B	C	D	E	F	H	J	Product No.	Material	Article No.	
Shear														
$F_{z \max}$	$s_{z \max}$	$c_{\text{shear}}$												
[N]	[mm]	[N/mm]	[mm]	[mm]	[mm]	[mm]	[mm]	[mm]	[mm]	[mm]				
120	6,1	20	61	20	43	27	25	20,4	10,0	6,6	5318 004	45 NR	96764	•
150	5,6	30	61	20	43	27	25	20,4	10,0	6,6	5318 004	50 NR	96763	•
160	4,3	40	61	20	43	27	25	20,4	10,0	6,6	5318 004	60 NR	96765	•
220	7,0	30	71	25	62	43	38	26,4	12,5	11,0	5318 003	50 NR	96769	•
300	5,2	60	71	25	62	43	38	26,4	12,5	11,0	5318 003	60 NR	96771	•
300	3,3	90	71	25	62	43	38	26,4	12,5	11,0	5318 003	70 NR	96770	•
850	7,0	120	79	50	78	56	51	32,4	25,0	13,5	5318 002	50 NR	96775	•
850	4,2	200	79	50	78	56	51	32,4	25,0	13,5	5318 002	60 NR	96777	•
980	3,0	330	79	50	78	56	51	32,4	25,0	13,5	5318 002	70 NR	96773	•
2000	7,0	290	87	65	108	83	76	38,4	32,5	17,5	5318 001	50 NR	96781	•
2000	3,5	570	87	65	108	83	76	38,4	32,5	17,5	5318 001	60 NR	96784	•
2000	2,8	710	87	65	108	83	76	38,4	32,5	17,5	5318 001	70 NR	96779	•

● Available from stock    ○ On request: Tool is available, delivery at short notice

Article list

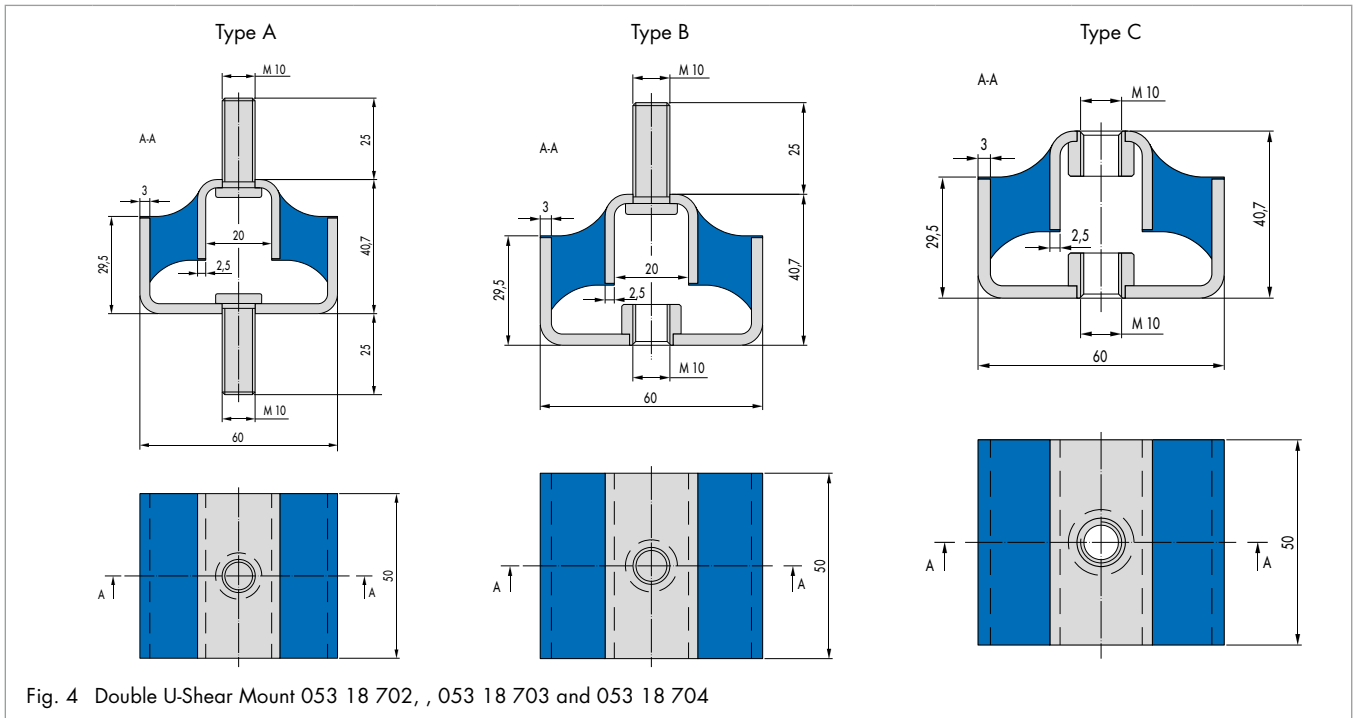

Fig. 4 Double U-Shear Mount 053 18 702, , 053 18 703 and 053 18 704

Nominal maxima		Stiffness	A	B	C	D	Type	F	H	J	Product No.	Material	Article No.	
Shear														
$F_{z \max}$	$s_{z \max}$	$c_{\text{shear}}$	[mm]	[mm]	[mm]	[mm]		[mm]	[mm]	[mm]				
[N]	[mm]	[N/mm]												
620	5	120	60	50	40	-	A	20	25	M10	5318 702	45 NR	49047097	○
1000	5	200	60	50	40	-	A	20	25	M10	5318 702	60 NR	49047098	○
1350	5	270	60	50	40	-	A	20	25	M10	5318 702	70 NR	49047099	○
620	5	120	60	50	40	-	B	20	25	M10	5318 703	45 NR	49047100	○
1000	5	200	60	50	40	-	B	20	25	M10	5318 703	60 NR	49047101	○
1350	5	270	60	50	40	-	B	20	25	M10	5318 703	70 NR	49054182	○
620	5	120	60	50	40	-	C	20		M10	5318 704	45 NR	49054183	○
1000	5	200	60	50	40	-	C	20		M10	5318 704	60 NR	49054184	○
1350	5	270	60	50	40	-	C	20		M10	5318 704	70 NR	49054185	○

● Available from stock    ○ On request: Tool is available, delivery at short notice



## Circular Mount

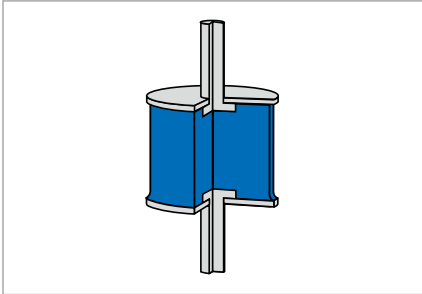

Fig. 1 Circular Mount

### Product description

Circular mounts are widely used components for adjustment of tension and manufacturing tolerances. They also function as protection against shock loading.

### Product advantages

- Uniform stiffness in the radial direction
- Easily installed hexagon version available
- RoHS-compliant.

### Application

Circular mounts are used to carry driven machinery, engines, compressors, pumps, test machines, and so on.

### Material

Standard material	Hardness
Natural rubber	45, 55, 60, 70, 75, 80 Shore A
Ethylene-acrylate rubber AEM	60 Shore A
Chloroprene rubber	45, 60 Shore A

### Operating conditions

Radial forces	14 N ... 24000 N	Maximum permissible force
Axial forces	18 N ... 80000 N	Maximum permissible force
Max. temperature	+60 °C, transient +80 °C	Natural rubber
Min. temperature	-45 °C	

**Material**

Standard material	Hardness
Natural rubber	45, 55, 60, 70, 75, 80 Shore A
Ethylene-acrylate rubber AEM	60 Shore A
Chloroprene rubber	45, 60 Shore A

**Operating conditions**

Radial forces	14 N ... 24000 N	Maximum permissible force
Axial forces	18 N ... 80000 N	Maximum permissible force
Max. temperature	+60 °C, transient +80 °C	Natural rubber
Min. temperature	-45 °C	

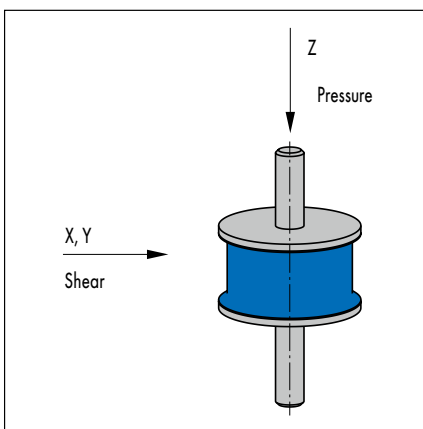

Fig. 2 Primary load directions

Circular mounts have a uniform stiffness in the shear directions X,Y. The compressive load stiffness  $F_{max}$  in the Z direction has, depending on the component, approx. 1 to 10 times the value of the stiffness in the shear directions. The primary load direction corresponds to the shear load X,Y since this is where the greatest isolation is to be achieved.

**Design notes**

The circular mount comprises two round or square metal discs joined by a vulcanised rubber layer. The metal discs can each have a threaded stud or threaded nut. The circular mounts are available with cylindrical contour as well as with constricted-body elastomer contour. Mounts with constricted-body contour can be specially designed with an elongation of ~10% for high dynamic loads in the horizontal direction. The constricted design provides for significantly higher durability with high dynamic loading with otherwise equal compressive deflection.

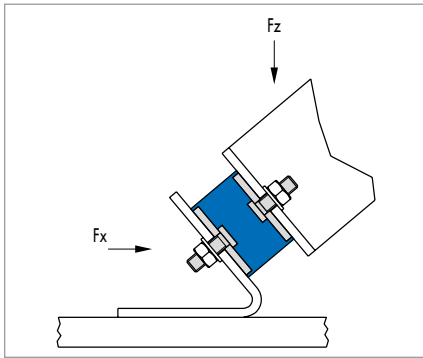

Fig. 3 Compressive and shear loading

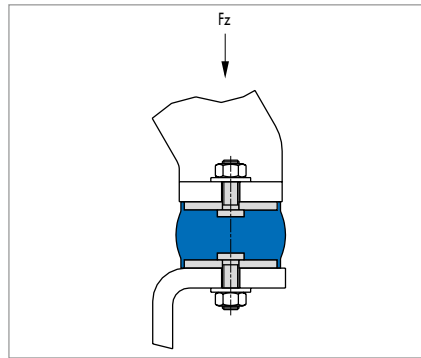

Fig. 4 Compressive loading

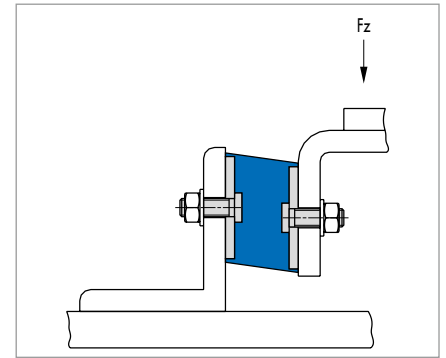

Fig. 5 Shear loading

### Fitting & installation

- Circular mounts are designed to be anchored by threaded fasteners
- Avoid non-load-dependent offset of the metal plates relative to each other
- Individual components permit slight adjustment to allow for in-situ offset
- The form of the boreholes to accommodate the threaded studs or securing screws must be compliant with DIN EN 20273
- The securing plates must be in full-surface contact with the mating faces
- It is important to ensure that the mating faces of the frame and the mass carried by the mount are flat and smooth
- When installing a mount that combines a circular securing plate at one end with a hexagonal plate at the other, always tighten the fastener for the circular plate first
- Minimum strength class for screws/nuts is 4.6.

**Article list Circular Mount Type A with constricted-body elastomer contour**

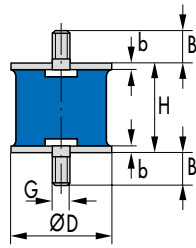
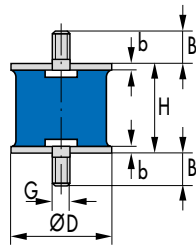

Fig. 6 Circular Mounts Type A, constricted-body elastomer contour

Nominal maxima		Stiffness	Nominal maxima		Stiffness	Outside Ø	Height	Threads	Length	Sheet thickness	Product No.	Material	Article No.	
Radial shear xy			Axial pressure z											
F <sub>S max</sub>	s <sub>S max</sub>	c <sub>shear</sub>	F <sub>D max</sub>	s <sub>D max</sub>	c <sub>pressure</sub>	D	H	G	B	b				
[N]	[mm]	[N/mm]	[N]	[mm]	[N/mm]	[mm]	[mm]		[mm]	[mm]				
14	3,0	0	18	0,8	20	10	9	M4	6,0	1,0	5218 242	45 NR 11	91015	•
40	4,0	10	50	0,7	70	10	9	M4	6,0	1,0	5218 242	60 NR 11	90505	•
30	3,0	10	45	0,7	60	15	8	M4	6,0	1,0	5218 129	45 NR 11	90872	•
80	3,0	30	100	0,6	170	15	8	M4	6,0	1,0	5218 129	60 NR 11	91007	•
24	4,0	10	51	1,5	30	15	15	M4	15,0	1,0	5218 058	45 NR 11	91019	•
50	4,0	10	120	1,5	80	15	15	M4	15,0	1,0	5218 058	60 NR 11	91008	•
40	2,0	20	100	0,4	250	16	6	M4	10,0	1,0	5218 057	45 NR 11	91014	•
100	2,0	50	150	0,5	300	16	6	M4	10,0	1,0	5218 057	60 NR 11	91695	•
45	4,0	10	110	1,3	80	20	15	M6	15,0	1,5	5218 039	45 NR 11	91397	•
115	4,0	30	250	1,3	190	20	15	M6	15,0	1,5	5218 039	60 NR 11	90589	•
65	7,0	10	80	2,0	40	20	20	M6	10,0	1,5	5218 149	45 NR 11	97176	•
50	6,5	10	100	1,8	60	20	20	M6	18,5	1,5	5218 061	45 NR 11	97165	•
140	8,0	20	160	1,8	90	20	20	M6	10,0	1,5	5218 149	60 NR 11	97175	•
100	6,5	20	195	1,8	110	20	20	M6	18,5	1,5	5218 061	60 NR 11	97164	•
65	9,0	10	75	2,3	30	20	25	M6	18,5	1,5	5218 095	45 NR 11	91393	•
140	11,0	10	160	2,4	70	20	25	M6	18,5	1,5	5218 095	60 NR 11	91064	•
110	7,0	20	140	2,0	70	25	20	M6	10,0	1,5	5218 132	45 NR 11	90678	•
110	7,0	20	140	2,0	70	25	20	M6	15,0	1,5	5218 086	45 NR 11	91055	•
220	9,0	20	240	1,8	130	25	20	M6	10,0	1,5	5218 132	60 AEM 23	470951	•
220	9,0	20	240	1,8	130	25	20	M6	10,0	1,5	5218 132	60 NR 11	90679	•
220	9,0	20	240	1,8	130	25	20	M6	15,0	1,5	5218 086	60 NR 11	90646	•
135	10,5	10	300	3,0	100	25	30	M6	18,5	1,5	5218 050	60 NR 11	90605	•
110	13,0	10	110	3,6	30	25	35	M6	18,5	1,5	5218 125	45 NR 11	92267	•
220	15,0	10	220	3,2	70	25	35	M6	18,5	1,5	5218 125	60 NR 11	90936	•
150	5,0	30	270	1,3	210	30	15	M8	23,0	2,0	5218 151	45 NR 11	92149	•
300	6,0	50	500	1,1	450	30	15	M8	23,0	2,0	5218 151	60 NR 11	90985	•
440	4,5	100	640	1,1	580	30	15	M8	23,0	2,0	5218 151	70 NR 11	480188	•
150	7,0	20	220	1,9	120	30	20	M8	13,0	2,0	5218 099	45 NR 11	97208	○
160	8,0	20	240	1,8	130	30	20	M8	23,0	2,0	5218 051	45 NR 11	97202	○
300	8,0	40	400	1,6	250	30	20	M8	13,0	2,0	5218 099	60 NR 11	97209	○
400	8,0	50	600	1,8	330	30	20	M8	23,0	2,0	5218 051	60 NR 11	97201	•
150	9,0	20	200	2,5	80	30	25	M8	23,0	2,0	5218 163	45 NR 11	91608	•
300	10,0	30	380	2,4	160	30	25	M8	23,0	2,0	5218 163	60 NR 11	91149	•
95	9,0	10	250	3,1	80	30	30	M8	23,0	2,0	5218 067	45 NR 11	91386	•
225	9,0	30	530	3,1	170	30	30	M8	23,0	2,0	5218 067	60 NR 11	91061	•
280	11,0	30	400	3,0	130	40	30	M8	22,5	2,5	5218 123	45 NR 11	90999	•
210	9,0	20	470	3,0	160	40	30	M10	27,5	2,5	5218 070	45 NR 11	91234	•

• Available from stock    ○ On request: Tool is available, delivery at short notice



Nominal maxima		Stiffness	Nominal maxima		Stiffness	Outside Ø	Height	Threads	Length	Sheet thickness	Product No.	Material	Article No.	
Radial shear xy			Axial pressure z			D	H	G	B	b				
F <sub>S max</sub>	s <sub>S max</sub>	c <sub>shear</sub>	F <sub>D max</sub>	s <sub>D max</sub>	c <sub>pressure</sub>						[N]	[mm]	[N/mm]	[mm]
[N]	[mm]	[N/mm]	[N]	[mm]	[N/mm]	[mm]	[mm]	[mm]	[mm]	[mm]				
210	9,0	20	470	3,0	160	40	30	M10	27,5	2,5	5218 070	45 NR 11	91234	•
550	12,0	45	920	3,0	310	40	30	M10	17,5	2,5	5218 018	60 NR 11	90574	•
550	12,0	45	920	3,0	310	40	30	M8	22,5	2,5	5218 123	60 NR 11	91091	•
550	12,0	45	920	3,0	310	40	30	M10	27,5	2,5	5218 070	60 NR 11	90634	•
725	12,0	60	1090	3,0	360	40	30	M10	27,5	2,5	5218 070	70 NR 11	91116	○
1000	12,0	85	1340	3,0	420	40	30	M8	22,5	2,5	5218 123	80 NR 11	90973	•
280	15,0	20	350	4,2	80	40	40	M8	22,5	2,5	5218 153	45 NR 11	90918	•
300	16,0	20	300	4,0	80	40	40	M8	27,5	2,5	5218 168	45 NR 11	93006	•
600	16,0	40	650	4,0	160	40	40	M8	22,5	2,5	5218 153	60 NR 11	90691	•
600	16,0	40	650	4,0	160	40	40	M10	27,5	2,5	5218 116	60 NR 11	90668	•
600	16,0	40	650	4,0	160	40	40	M8	27,5	2,5	5218 168	60 NR 11	90744	•
900	7,0	130	1800	1,7	1060	50	20	M10	27,5	2,5	5218 232	60 NR 11	90734	•
450	10,0	50	700	3,0	230	50	30	M10	17,5	2,5	5218 089	45 NR 11	90108	•
425	10,0	40	850	3,0	280	50	30	M10	27,5	2,5	5218 040	45 NR 11	92162	•
900	11,0	80	1300	2,7	480	50	30	M10	17,5	2,5	5218 089	60 NR 11	90649	•
940	10,0	90	1940	3,0	650	50	30	M10	27,5	2,5	5218 040	60 NR 11	91279	•
1300	10,0	130	1980	3,0	660	50	30	M10	27,5	2,5	5218 040	70 NR 11	90451	•
450	15,0	30	800	4,0	200	50	40	M10	27,5	2,5	5218 072	45 NR 11	90915	•
900	15,0	60	1100	4,0	280	50	40	M10	17,5	2,5	5218 104	60 NR 11	91145	•
720	15,0	50	1400	4,0	350	50	40	M10	27,5	2,5	5218 072	60 NR 11	90636	•
450	17,0	30	550	4,8	110	50	45	M10	27,5	2,5	5218 174	45 NR 11	90747	•
900	17,0	50	1000	4,2	240	50	45	M10	27,5	2,5	5218 174	60 NR 11	90924	○
1200	17,0	70	1400	4,2	330	50	45	M10	27,5	2,5	5218 174	70 NR 11	461948	•
450	19,0	20	500	5,4	90	50	50	M10	27,5	2,5	5218 110	45 NR 11	92076	•
900	20,0	50	1000	4,5	220	50	50	M10	27,5	2,5	5218 110	60 NR 11	90662	•
1300	18,0	70	1600	4,5	360	60	45	M10	19,5	2,5	5218 273	60 NR 11	91784	•
900	17,0	50	1400	4,8	290	70	45	M10	27,5	2,5	5218 206	45 NR 11	90396	•
1800	18,0	100	2400	4,5	530	70	45	M10	27,5	2,5	5218 206	60 NR 11	90771	•
200	20,0	10	600	8,0	80	70	60	M12	37,0	3,0	5218 075	45 NR 11	90322	•
1200	20,0	60	3200	8,0	400	70	60	M12	37,0	3,0	5218 075	60 NR 11	91036	•
980	7,0	140	4750	3,1	1530	75	25	M12	37,0	3,0	5218 078	45 NR 11	91185	•
2300	7,0	330	10700	3,1	3450	75	25	M12	37,0	3,0	5218 078	60 NR 11	91257	○
2800	7,0	400	10630	3,1	3430	75	25	M12	37,0	3,0	5218 078	70 NR 11	49014357	•
1000	14,0	70	1800	4,1	440	75	40	M12	25,0	3,0	5218 272	45 NR 11	97237	•
1300	16,0	80	1670	3,7	450	75	40	M12	37	3	5218 196	45 NR 11	97223	•
2100	16,0	130	3000	3,7	810	75	40	M12	37	3	5218 196	60 NR 11	97224	•
1950	18,0	110	3600	5,0	720	75	50	M12	37	3	5218 052	60 NR 11	91065	•
1000	20,0	50	1500	5,9	250	75	55	M12	37	3	5218 210	45 NR 11	90452	•
2100	22,0	100	2400	5,3	450	75	55	M12	37	3	5218 210	60 NR 11	91077	•

• Available from stock    ○ On request: Tool is available, delivery at short notice

Elastomer Dampers

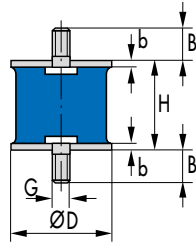

Nominal maxima		Stiffness	Nominal maxima		Stiffness	Outside Ø	Height	Threads	Length	Sheet thickness	Product No.	Material	Article No.	
Radial shear xy			Axial pressure z											
F <sub>S max</sub>	s <sub>S max</sub>	c <sub>shear</sub>	F <sub>D max</sub>	s <sub>D max</sub>	c <sub>pressure</sub>	D	H	G	B	b				
[N]	[mm]	[N/mm]	[N]	[mm]	[N/mm]	[mm]	[mm]		[mm]	[mm]				
2100	27,0	80	2000	6,5	310	75	70	M12	37	3	5218 113	60 NR 11	90665	•
5000	30,0	170	6000	7,2	830	75	70	M12	37	3	5218 113	80 NR 11	92303	•
2000	14,0	140	4000	3,8	1050	100	40	M16	36	4	5218 131	45 NR 11	97185	•
1750	12,0	150	5000	4,0	1250	100	40	M16	46	4	5218 016	45 NR 11	97184	•
3400	12,0	280	9700	4,0	2430	100	40	M16	46	4	5218 016	60 NR 11	97183	•
2000	20,0	100	3000	5,6	540	100	55	M16	46	4	5218 100	45 NR 11	92137	•
3800	21,0	180	5000	5,4	930	100	55	M16	46	4	5218 100	60 NR 11	90657	•
7000	25,0	280	9000	5,4	1670	100	55	M16	46	4	5218 100	70 NR 11	92090	•
2000	28,0	70	2600	8,0	330	100	75	M16	46	4	5218 083	45 NR 11	90644	•
3800	32	120	4200	7,5	560	100	75	M16	46	4	5218 083	60 NR 11	91135	•
10000	27	370	15000	8	1880	160	75	M16	46	4	5218 159	60 NR 11	90694	•
10000	41	240	10000	6,5	1538	160	114	M16	44	6	5218 178	70 NR 11	92001	•

• Available from stock    ○ On request: Tool is available, delivery at short notice

**Article list Circular Mount Type A with cylindrical elastomer contour**

Fig. 7 Circular Mounts Type A, cylindrical elastomer contour

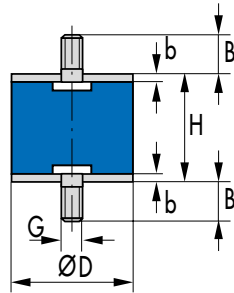

Nominal maxima				Outside Ø	Height	Threads	Length	Sheet thickness	Product No.	Material	Article No.	
Radial shear		Axial pressure										
F <sub>S max</sub>	s <sub>S max</sub>	F <sub>D max</sub>	s <sub>D max</sub>	D	H	G	B	b				
[N]	[mm]	[N]	[mm]	[mm]	[mm]		[mm]	[mm]				
26	1,60	48	0,64	13	10	M5	10	1,0	A 1310	55 NR	509003	•
26	2,60	40	1,00	13	15	M5	10	1,0	A 1315	55 NR	509007	•
26	2,60	40	1,00	13	20	M5	10	1,0	A 1320	55 NR	509015	•
34	1,00	95	0,40	15	8	M4	12	1,5	A 1508	55 NR	509018	•
34	1,40	75	0,56	15	10	M4	12	1,5	A 1510	55 NR	509019	•
34	2,39	58	1,00	15	15	M4	12	1,5	A 1515	55 NR	509020	•
34	3,39	52	1,36	15	20	M4	12	1,5	A 1520	55 NR	509022	•
34	5,40	48	2,16	15	30	M4	12	1,5	A 1530	55 NR	509048	•
39	1,40	89	0,56	16	10	M5	12	1,5	A 1610	55 NR	509049	•
39	2,40	67	1,00	16	15	M5	12	1,5	A 1615	55 NR	509050	•
39	3,41	60	1,36	16	20	M5	12	1,5	A 1620	55 NR	509051	•
39	4,40	60	1,87	16	25	M5	12	1,5	A 1625	55 NR	509052	•
61	1,00	220	0,40	20	8,5	M6	16	2,0	A 208,5	55 NR	509053	•
61	2,20	121	0,88	20	15	M6	16	2,0	A 2015	55 NR	509056	•
61	3,20	103	1,28	20	20	M6	16	2,0	A 2020	55 NR	509063	•
61	4,19	95	1,68	20	25	M6	16	2,0	A 2025	55 NR	509064	•
61	5,20	95	2,19	20	30	M6	16	2,0	A 2030	55 NR	509065	•
61	0,77	184	0,25	25	10	M8	20	2,0	A 2510	55 NR	509067	•
95	2,20	216	0,88	25	15	M6	18	2,0	A 2515	55 NR	509069	•
95	2,20	216	0,88	25	15	M8	20	2,0	A 2515	55 NR	509070	•
95	3,20	176	1,28	25	20	M6	18	2,0	A 2520	55 NR	509071	•
95	3,60	176	1,52	25	22	M8	20	2,0	A 2522	55 NR	509072	•
95	4,21	158	1,68	25	25	M6	18	2,0	A 2525	55 NR	509073	•
95	4,21	158	1,68	25	25	M8	20	2,0	A 2525	55 NR	509074	•
95	5,19	148	2,08	25	30	M8	20	2,0	A 2530	55 NR	509075	•
95	7,20	137	2,88	25	40	M8	20	2,0	A 2540	55 NR	509077	•
137	2,20	353	0,88	30	15	M8	25	2,0	A 3015	55 NR	509119	•
137	3,20	277	1,28	30	20	M8	25	2,0	A 3020	55 NR	509120	•
137	3,60	277	1,53	30	22	M8	25	2,0	A 3022	55 NR	509121	•
137	5,20	225	2,09	30	30	M8	25	2,0	A 3030	55 NR	509122	•
137	7,20	206	2,88	30	40	M8	25	2,0	A 3040	55 NR	509123	•
243	3,20	588	1,28	40	20	M10	25	2,0	A 4020	55 NR	509124	•
243	4,80	464	1,92	40	28	M10	25	2,0	A 4028	55 NR	509125	•
243	5,20	464	2,16	40	30	M8	23	2,0	A 4030	55 NR	509126	•
243	6,21	417	2,48	40	35	M10	25	2,0	A 4035	55 NR	509127	•
243	7,20	417	3,04	40	40	M8	23	2,0	A 4040	55 NR	509128	•

• Available from stock    ○ On request: Tool is available, delivery at short notice

Elastomer Dampers

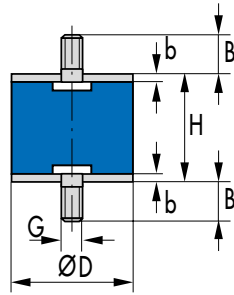

Nominal maxima				Outside Ø	Height	Threads	Length	Sheet thickness	Product No.	Material	Article No.	
Radial shear		Axial pressure										
F <sub>S max</sub>	s <sub>S max</sub>	F <sub>D max</sub>	s <sub>D max</sub>	D	H	G	B	b				
[N]	[mm]	[N]	[mm]	[mm]	[mm]		[mm]	[mm]				
243	7,20	417	3,04	40	40	M10	25	2,0	A 4040	55 NR	509129	•
243	8,19	381	3,28	40	45	M10	25	2,0	A 4045	55 NR	509130	•
380	2,99	1153	1,20	50	20	M10	25	2,5	A 5020	55 NR	509131	•
380	4,00	919	1,60	50	25	M10	25	2,5	A 5025	55 NR	509132	•
380	5,00	798	2,00	50	30	M10	25	2,5	A 5030	55 NR	509133	•
380	6,00	725	2,40	50	35	M10	25	2,5	A 5035	55 NR	509134	•
380	7,00	677	2,80	50	40	M10	25	2,5	A 5040	55 NR	509135	•
380	8,00	677	3,37	50	45	M10	25	2,5	A 5045	55 NR	509136	•
380	9,01	618	3,59	50	50	M10	25	2,5	A 5050	55 NR	509137	•
547	4,00	1519	1,60	60	25	M10	25	2,5	A 6025	55 NR	509138	•
547	6,20	1129	2,48	60	36	M10	25	2,5	A 6036	55 NR	509139	•
547	8,00	996	3,20	60	45	M10	25	2,5	A 6045	55 NR	509140	•
745	5,82	1759	2,32	70	35	M10	25	3,0	A 7035	55 NR	509141	•
745	8,80	1391	3,52	70	50	M10	25	3,0	A 7050	55 NR	509142	•
745	12,80	1205	5,13	70	70	M10	25	3,0	A 7070	55 NR	509144	•
855	3,80	3039	1,52	75	25	M12	35	3,0	A 7525	55 NR	509145	•
855	6,79	1905	2,72	75	40	M12	35	3,0	A 7540	55 NR	509146	•
855	8,80	1591	3,39	75	50	M12	35	3,0	A 7550	55 NR	509147	•
855	9,80	1591	3,98	75	55	M12	35	3,0	A 7555	55 NR	509148	•
973	4,79	2952	1,92	80	30	M14	35	3,0	A 8030	55 NR	509149	•
973	6,81	2259	2,72	80	40	M14	35	3,0	A 8040	55 NR	509150	•
973	12,81	1647	5,11	80	70	M14	35	3,0	A 8070	55 NR	509151	•
973	14,79	1647	6,21	80	80	M14	35	3,0	A 8080	55 NR	509153	•
1521	6,79	4153	2,71	100	40	M16	47	3,0	A 10040	55 NR	509154	•
1521	9,81	3231	3,92	100	55	M16	47	3,0	A 10055	55 NR	509155	•
1521	14,76	2649	5,91	100	80	M16	47	3,0	A 10080	55 NR	509156	•

● Available from stock    ○ On request: Tool is available, delivery at short notice



**Article list Circular Mount Type A SW XX with hexagonal plate and constricted-body elastomer contour**

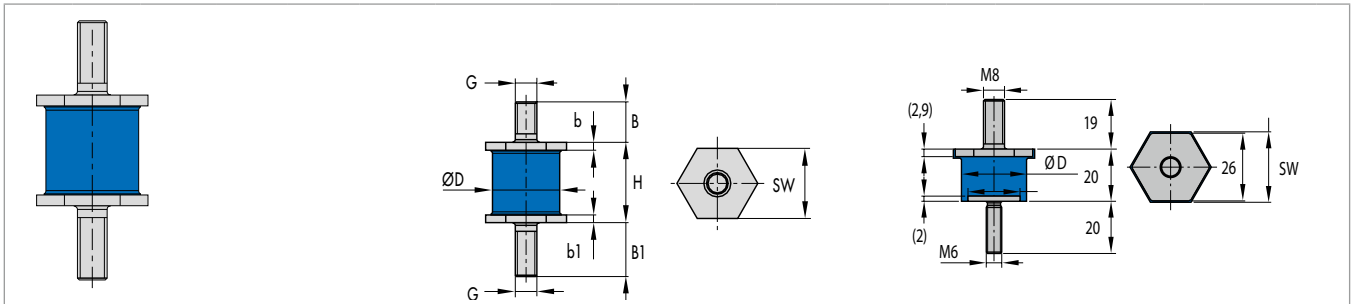

Fig. 8 Circular Mounts hexagonal Type A, constricted body contour

Fig. 9 Special design

Nominal maxima			Stiffness			Outside Ø	Height	Rubber Ø	Threads	Threaded length		Metal sheet thickness		Product No.	Material	Article No.	
Radial shear			Axial pressure							B	B <sub>1</sub>	b	b <sub>1</sub>				
F <sub>S</sub> <sub>max</sub>	s <sub>S</sub> <sub>max</sub>	c <sub>shear</sub>	F <sub>D</sub> <sub>max</sub>	s <sub>D</sub> <sub>max</sub>	c <sub>pres-sure</sub>	SW (width across flats)	H	D	G	B	B <sub>1</sub>	b	b <sub>1</sub>				
[N]	[mm]	[N/mm]	[N]	[mm]	[N/mm]	[mm]	[mm]	[mm]		[mm]	[mm]	[mm]					
70	4,4	15,9	160	1,5	107	SW21	15	18	M6	16	-	2,0	-	052 18 898	45 CR 57	49004238	○
60	6,4	9,4	145	2,4	60	SW21	20	18	M6	16	-	2,0	-	052 18 895	45 NR 97	49016672	○
60	6,4	9,4	145	2,4	60	SW21	20	18	M6	16	-	2,0	-	052 18 895	45 CR 57	49002825	○
100	6,4	15,6	245	2,4	102	SW21	20	18	M6	16	-	2,0	-	052 18 895	60 CR 57	49011379	○
100	6,4	15,6	245	2,4	102	SW21	20	18	M6	28	16	2,0	-	052 18 906	60 CR 57	49038588	○
95	9,0	10,6	250	3,1	81	SW26	34	25	M8	19	-	2,9	-	052 18 921	45 CR 57	49039149	○
95	9,0	10,6	250	3,1	81	SW26	34	25	M8	12	-	2,9	-	052 18 920	45 CR 57	49039148	○
150	9,0	16,7	200	2,5	80	SW27/Ø25	20	25	M8/M6	19	20	2,9	2	052 18 924	45 CR 57	49039020	○

● Available from stock ○ On request: Tool is available, delivery at short notice

**Article list Circular Mount Type 052 18 389  
(Circular Mount Type A with constricted-body elastomer contour, notched)**

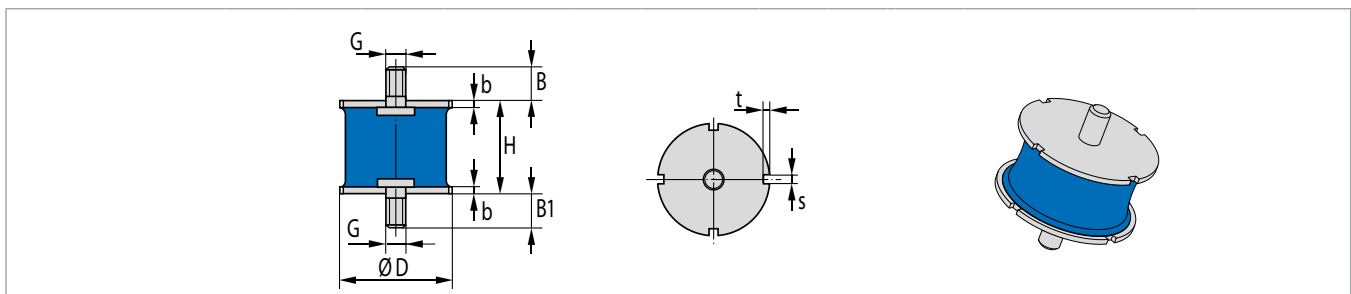

Fig. 9 Circular Mount Type 052 18 389

Nominal maxima			Stiffness			Outside Ø	Height	Threads	Threaded length		Metal sheet thickness	Product No.	Material	Article No.	
Radial shear			Axial pressure						D	H					
F <sub>S</sub> <sub>max</sub>	s <sub>S</sub> <sub>max</sub>	c <sub>shear</sub>	F <sub>D</sub> <sub>max</sub>	s <sub>D</sub> <sub>max</sub>	c <sub>pres-sure</sub>	D	H	G	B	B <sub>1</sub>	b				
[N]	[mm]	[N/mm]	[N]	[mm]	[N/mm]	[mm]	[mm]	[mm]	[mm]	[mm]	[mm]				
1600	20	80	3000	6	500	105	55	M16	36	26	4	5218 389	A NR	49037737	○
2200	20	110	4100	6	690	105	55	M16	36	26	4	5218 389	B NR	49037738	○
3000	20	150	5600	6	940	105	55	M16	36	26	4	5218 389	C NR	49037739	○
4000	20	200	7500	6	1250	105	55	M16	36	26	4	5218 389	D NR	49037740	○

● Available from stock ○ On request: Tool is available, delivery at short notice

Elastomer Dampers

**Article list Circular Mount Type B with constricted-body elastomer contour**

Fig. 10 Circular Mounts Type B, constricted-body elastomer contour

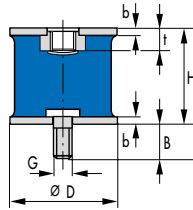

Nominal maxima			Stiffness			Nominal maxima			Stiffness			Out-side Ø	Height	Threads	Length	Screw-in depth (max.)	Sheet thickness	Product No.	Material	Article No.
Radial shear			Axial pressure			D	H	G	B	t	b									
F <sub>S max</sub>	s <sub>S max</sub>	c <sub>shear</sub>	F <sub>D max</sub>	s <sub>D max</sub>	c <sub>pressure</sub>							[N]	[mm]	[N/mm]	[mm]	[mm]	[mm]			
[N]	[mm]	[N/mm]	[N]	[mm]	[N/mm]	[mm]	[mm]	[N/mm]	[mm]	[mm]	[mm]									
14	3,0	0	18	0,8	20	10	9	M4	6,0	3,5	1,0	5218 251	45 NR 11	91158	•					
40	4,0	10	50	0,7	70	10	9	M4	6,0	3,5	1,0	5218 251	60 NR 11	90786	•					
40	4,0	10	80	1,5	50	15	15	M4	15,0	4,0	1,0	5218 059	45 NR 11	90614	•					
70	4,0	20	150	1,5	100	15	15	M4	15,0	4,0	1,0	5218 059	60 NR 11	90615	•					
65	7,0	10	80	2,0	40	20	20	M6	10,5	6,5	1,5	5218 137	45 NR 11	97170	•					
140	8,0	20	160	1,8	90	20	20	M6	10,5	6,5	1,5	5218 137	60 AEM 33	49003891	•					
140	8,0	20	160	1,8	90	20	20	M6	10,5	6,5	1,5	5218 137	60 NR 11	97169	•					
230	7,5	30	260	1,9	140	20	20	M6	10,5	6,5	1,5	5218 137	70 NR 11	97171	•					
320	7,0	50	360	2,0	180	20	20	M6	10,5	6,5	1,5	5218 137	80 NR 11	97172	•					
90	7,0	10	170	2,1	80	20	20	M6	18,5	5,8	1,5	5218 062	45 NR 11	97166	•					
170	7,0	20	320	2,1	150	20	20	M6	18,5	5,8	1,5	5218 062	60 NR 11	97167	•					
65	9,0	10	75	2,3	30	20	25	M6	18,5	5,8	1,5	5218 096	45 NR 11	91865	•					
140	11,0	10	160	2,4	70	20	25	M6	18,5	5,8	1,5	5218 096	60 NR 11	91519	•					
110	7,0	20	140	2,0	70	25	20	M6	10,0	5,8	1,5	5218 150	45 NR 11	91514	•					
110	7,0	20	140	2,0	70	25	20	M6	15,0	5,8	1,5	5218 087	45 NR 11	91192	•					
220	9,0	20	240	1,8	130	25	20	M6	15,0	5,8	1,5	5218 087	60 NR 11	90647	•					
100	12,1	10	200	3,7	50	25	30	M6	18,5	5,8	1,5	5218 063	45 NR 11	91839	•					
240	12,1	20	480	3,7	130	25	30	M6	18,5	5,8	1,5	5218 063	60 NR 11	91163	•					
220	15,0	10	220	3,2	70	25	35	M6	18,5	5,8	1,5	5218 126	60 NR 11	91617	•					
300	8,0	40	400	1,6	250	30	20	M8	13,0	7,4	2,0	5218 195	60 NR 11	97210	•					
450	8,0	60	550	1,6	340	30	20	M8	13,0	7,4	2,0	5218 195	70 NR 11	97211	•					
900	8,0	110	750	1,6	470	30	20	M8	13,0	7,4	2,0	5218 195	80 NR 11	97212	•					
240	6,3	40	700	2,0	350	30	20	M8	23,0	7,4	2,0	5218 065	45 NR 11	597205	•					
500	6,3	80	1240	2,0	630	30	20	M8	23,0	7,4	2,0	5218 065	60 NR 11	97206	•					
160	11,3	10	300	3,4	90	30	30	M8	23,0	7,4	2,0	5218 068	45 NR 11	91441	•					
380	11,3	30	700	3,4	210	30	30	M8	23,0	7,4	2,0	5218 068	60 NR 11	90632	•					
300	11,0	30	280	3,0	90	40	30	M8	22,5	7,9	2,5	5218 124	45 NR 11	91000	•					
600	11,0	50	700	3,0	230	40	30	M8	22,5	7,9	2,5	5218 124	60 NR 11	90671	•					
900	11,0	80	1200	3,0	400	40	30	M8	22,5	7,9	2,5	5218 124	70 NR 11	92476	•					
280	10,0	30	550	3,0	180	40	30	M10	27,5	10,0	2,5	5218 071	45 NR 11	91107	•					
670	10,0	70	1300	3,0	430	40	30	M10	27,5	10,0	2,5	5218 071	60 NR 11	90635	•					
980	10,0	100	1800	3,0	600	40	30	M10	27,5	10,0	2,5	5218 071	70 NR 11	91654	•					
280	15,0	20	350	4,2	80	40	40	M8	22,5	7,9	2,5	5218 152	45 NR 11	92089	•					
600	16,0	40	650	4,0	160	40	40	M8	22,5	7,9	2,5	5218 152	60 NR 11	91561	•					
300	19,0	20	300	5,2	60	45	50	M8	22,5	7,9	2,5	5218 187	45 NR 11	91079	•					
700	19,0	40	800	5,2	150	45	50	M8	22,5	7,9	2,5	5218 187	60 NR 11	90758	•					
350	11,0	30	500	2,7	190	50	30	M10	17,5	10,0	2,5	5218 090	45 NR 11	91468	•					
900	11,0	80	1300	2,7	480	50	30	M10	17,5	10,0	2,5	5218 090	60 NR 11	91254	•					
1200	11,0	110	1800	2,7	670	50	30	M10	17,5	10,0	2,5	5218 090	70 NR 11	91321	•					
1000	10,0	100	1900	3,0	630	50	30	M10	27,5	10,0	2,5	5218 046	60 NR 11	90601	•					

• Available from stock    ○ On request: Tool is available, delivery at short notice

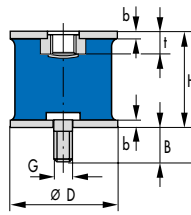

Nominal maxima			Stiffness			Nominal maxima			Stiffness			Out-side Ø	Height	Threads	Length	Screw-in depth (max.)	Sheet thickness	Product No.	Material	Article No.
Radial shear			Axial pressure			F <sub>S max</sub>	s <sub>S max</sub>	c <sub>shear</sub>	F <sub>D max</sub>	s <sub>D max</sub>	c <sub>pressure</sub>									
[N]	[mm]	[N/mm]	[N]	[mm]	[N/mm]							[mm]	[mm]	[mm]	[mm]	[mm]	[mm]			
1020	15,1	70	1860	4,6	400	50	40	M10	27,5	10,0	2,5	5218 073	60 NR 11	91312	•					
450	19,0	20	500	5,4	90	50	50	M10	27,5	10,0	2,5	5218 111	45 NR 11	92075	•					
900	20,0	50	1000	4,5	220	50	50	M10	27,5	10,0	2,5	5218 111	60 NR 11	90844	•					
1300	18,0	70	1600	4,5	360	60	45	M10	19,0	10,0	2,5	5218 274	60 NR 11	91476	•					
650	17,0	40	900	4,8	190	60	45	M10	19,5	10,5	2,5	5218 274	45 NR 11	92502	•					
900	17,0	50	1400	4,8	290	70	45	M10	27,5	10,5	2,5	5218 200	45 NR 11	91607	•					
1800	18,0	100	2400	4,5	530	70	45	M10	27,5	10,5	2,5	5218 200	60 NR 11	90768	•					
800	24,9	30	1450	7,5	190	70	60	M12	37,0	10,5	3,0	5218 076	45 NR 11	92004	•					
1450	24,9	60	2750	7,5	370	70	60	M12	37,0	10,5	3,0	5218 076	60 NR 11	90639	•					
1000	14,0	70	1800	4,1	440	75	40	M12	37,0	10,5	3,0	5218 197	45 NR 11	97227	•					
2100	16,0	130	3000	3,7	810	75	40	M12	37,0	10,5	3,0	5218 197	60 NR 11	97226	•					
3200	15,0	210	5000	4,0	1250	75	40	M12	37,0	10,5	3,0	5218 197	70 NR 11	97228	•					
1150	20,0	60	2100	6,0	350	75	50	M12	37,0	10,5	3,0	5218 081	45 NR 11	91575	•					
1200	20,0	60	4200	6,0	700	75	50	M12	37,0	10,5	3,0	5218 081	60 NR 11	90642	•					
2100	22,0	100	2400	5,3	450	75	55	M12	37,0	10,5	3,0	5218 211	60 NR 11	92459	•					
3200	21,0	150	4000	5,7	700	75	55	M12	37,0	10,5	3,0	5218 211	70 NR 11	90899	•					
1000	26,0	40	1400	7,7	180	75	70	M12	37,0	10,5	3,0	5218 114	45 NR 11	92491	•					
2100	27,0	80	2000	6,5	310	75	70	M12	37,0	10,5	3,0	5218 114	60 NR 11	90666	•					
2000	14,0	140	4000	3,5	1140	100	40	M16	36,0	15,8	4,0	5218 156	45 NR 11	597187	•					
3800	14,0	270	7000	3,5	2000	100	40	M16	36,0	15,8	4,0	5218 156	60 NR 11	97186	•					
6000	14,0	430	12000	3,5	3430	100	40	M16	36,0	15,8	4,0	5218 156	70 NR 11	92744	•					
6600	14,0	470	16800	3,5	4800	100	40	M16	36,0	15,8	4,0	5218 156	80 NR 11	92046	•					
1900	12,0	160	4500	3,5	1290	100	40	M16	46,0	15,8	4,0	5218 015	45 NR 11	97182	•					
4500	12,0	380	10100	3,5	2890	100	40	M16	46,0	15,8	4,0	5218 015	60 NR 11	97181	•					
7200	12,0	600	17500	3,5	5000	100	40	M16	46,0	15,8	4,0	5218 015	70 NR 11	92152	•					
1800	19,0	90	2500	5,4	460	100	55	M16	46,0	15,8	4,0	5218 101	45 NR 11	500635	•					
3300	19,0	170	5000	5,4	930	100	55	M16	46,0	15,8	4,0	5218 101	60 NR 11	90658	•					
5300	19,0	280	8000	5,4	1480	100	55	M16	46,0	15,8	4,0	5218 101	70 NR 11	92087	•					
8000	19,0	420	12000	5,4	2220	100	55	M16	46,0	15,8	4,0	5218 101	80 NR 11	91108	•					
3800	32,0	120	4200	7,5	560	100	75	M16	46,0	15,8	4,0	5218 084	60 NR 11	92274	•					
5000	30,0	170	9000	8,0	1130	160	75	M16	46,0	15,8	4,0	5218 158	45 NR 11	92530	○					
10000	30,0	330	15000	8,0	1880	160	75	M16	46,0	15,8	4,0	5218 158	60 NR 11	90693	•					
13800	30,0	460	21000	8,0	2630	160	75	M16	46,0	15,8	4,0	5218 158	70 NR 11	92458	○					
24000	30,0	800	40000	8,0	5000	160	75	M16	46,0	15,8	4,0	5218 158	80 NR 11	91795	•					
8000	36,0	220	80000	9,0	8890	160	114	M16	44,0	15,8	6,0	5218 179	60 NR 11	90752	•					

• Available from stock    ○ On request: Tool is available, delivery at short notice

Elastomer Dampers

**Article list Circular Mount Type B with cylindrical elastomer contour**

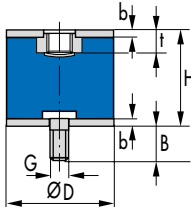
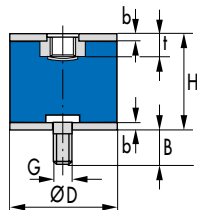

Fig. 11 Circular Mounts Type B, cylindrical elastomer contour

Nominal maxima				Outside Ø	Height	Threads	Length	Screw-in depth (max.)	Sheet thickness	Product No.	Material	Article No.	
Radial shear		Axial pressure											
F <sub>S max</sub>	s <sub>S max</sub>	F <sub>D max</sub>	s <sub>D max</sub>	D	H	G	B	t	b				
[N]	[mm]	[N]	[mm]	[mm]	[mm]		[mm]	[mm]	[mm]				
30,6	1,3	67,5	0,5	15	15	M4	12	3	1,5	B 1515	55 NR	509078	•
30,6	4,9	80	0,5	16	10	M5	12	3	1,5	B 1610	55 NR	509079	•
35,1	1,3	61	0,9	16	15	M5	12	3	1,5	B 1615	55 NR	509080	•
35,1	2,2	54	1,2	16	20	M5	12	3	1,5	B 1620	55 NR	509081	•
35,1	4,0	51	1,6	16	25	M5	12	3	1,5	B 1625	55 NR	509082	•
55,0	2,0	109	0,8	20	15	M6	16,5	4	2,0	B 2015	55 NR	509083	•
54,9	2,9	93	1,2	20	20	M6	16,5	4	2,0	B 2020	55 NR	509085	•
54,9	3,8	85	1,5	20	25	M6	16,5	4	2,0	B 2025	55 NR	509086	•
54,9	4,7	81	1,8	20	30	M6	16,5	5	2,0	B 2030	55 NR	509087	•
85,5	2,0	158	1,2	25	20	M8	20	5	2,0	B 2520	55 NR	509091	•
85,5	2,9	151	1,3	25	22	M8	20	6	2,0	B 2522	55 NR	509094	•
85,5	3,8	142	1,5	25	25	M8	20	6	2,0	B 2525	55 NR	509095	•
85,5	3,8	133	1,9	25	30	M8	20	6	2,0	B 2530	55 NR	509096	•
85,5	4,7	124	2,6	25	40	M8	20	6	2,0	B 2540	55 NR	509097	•
85,5	6,5	317	0,8	30	15	M8	25	6	2,0	B 3015	55 NR	509098	•
123,3	2,0	250	1,2	30	20	M8	25	6	2,0	B 3020	55 NR	509099	•
123,3	2,9	235	1,3	30	22	M8	25	6	2,0	B 3022	55 NR	509100	•
123,3	3,2	203	1,9	30	30	M8	25	6	2,0	B 3030	55 NR	509101	•
123,3	4,7	185	2,6	30	40	M8	25	6	2,0	B 3040	55 NR	509102	•
218,7	4,3	530	1,2	40	20	M10	25	8	2,0	B 4020	55 NR	509103	•
218,7	4,7	418	1,7	40	28	M10	25	8	2,0	B 4028	55 NR	509104	•
218,7	5,6	403	1,9	40	30	M10	25	8	2,0	B 4030	55 NR	509105	•
219,0	6,5	375	2,2	40	35	M10	25	8	2,0	B 4035	55 NR	509106	•
219,0	2,9	356	2,6	40	40	M10	25	8	2,0	B 4040	55 NR	509107	•
219,0	6,5	342	3,0	40	45	M10	25	8	2,0	B 4045	55 NR	509108	•
218,7	7,4	1038	1,1	50	20	M10	25	8	2,5	B 5020	55 NR	509109	•
342,0	3,6	718	1,8	50	30	M10	25	8	2,5	B 5030	55 NR	509110	•
342,0	4,5	653	2,2	50	35	M10	25	8	2,5	B 5035	55 NR	509111	•
342,0	5,4	610	2,5	50	40	M10	25	8	2,5	B 5040	55 NR	509112	•
342,0	6,3	563	2,8	50	45	M10	25	8	2,5	B 5045	55 NR	509113	•
342,0	7,2	556	3,2	50	50	M10	25	8	2,5	B 5050	55 NR	509114	•
492,3	3,6	1016	2,2	60	36	M10	25	8	2,5	B 6036	55 NR	509115	•
492,3	5,6	896	2,9	60	45	M10	25	8	2,5	B 6045	55 NR	509116	•
429,0	7,2	1583	2,1	70	35	M10	25	9	3,0	B 7035	55 NR	509117	•
670,5	5,2	1252	3,2	70	50	M10	25	9	3,0	B 7050	55 NR	509207	•
671,0	7,9	1252	3,2	70	70	M10	25	9	3,0	B 7070	55 NR	509208	•
770,0	3,4	1714	2,5	75	40	M12	35	8	3	B 7540	55 NR	509209	•
769,5	7,0	1581	2,8	75	45	M12	35	8	3	B 7545	55 NR	509210	•
770,0	6,1	1485	3,2	75	50	M12	35	8	3	B 7550	55 NR	509211	•

• Available from stock    ○ On request: Tool is available, delivery at short notice



Nominal maxima				Outside Ø	Height	Threads	Length	Screw-in depth (max.)	Sheet thickness	Product No.	Material	Article No.	
Radial shear		Axial pressure											
F <sub>S max</sub>	s <sub>S max</sub>	F <sub>D max</sub>	s <sub>D max</sub>	D	H	G	B	t	b				
[N]	[mm]	[N]	[mm]	[mm]	[mm]		[mm]	[mm]	[mm]				
875,7	4,3	2033	2,5	80	40	M14	35	12	3	B 8040	55 NR	509212	•
973,0	13,4	1620	5,4	80	70	M14	35	12	3	B 8070	55 NR	509213	•
973,0	14,8	1647	6,2	80	80	M14	35	12	3	B 8080	55 NR	509214	•
1369,0	6,1	3575	2,6	100	40	M16	45	16	3	B 10040	55 NR	509215	•
1521,0	9,8	3231	3,9	100	55	M16	45	16	3	B 10055	55 NR	509216	•
1521,0	14,8	2649	5,9	100	80	M16	45	16	3	B 10080	55 NR	509217	•
1520,0	18,8	2440	7,5	100	100	M16	45	16	3	B 100100	55 NR	509218	•

- Available from stock
- On request: Tool is available, delivery at short notice

**Article list Circular Mount Type C with constricted-body elastomer contour**

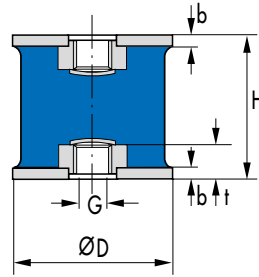
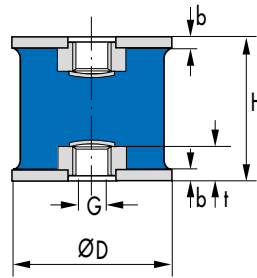

Fig. 12 Circular Mounts Type C, constricted-body elastomer contour

Nominal maxima		Stiffness	Nominal maxima		Stiffness	Out-side Ø	Height	Threads	Screw-in depth max.	Sheet thickness	Product No.	Material	Article No.
Radial shear			Axial pressure										
F <sub>S</sub> max	s <sub>S</sub> max	c <sub>shear</sub>	F <sub>S</sub> max	s <sub>S</sub> max	c <sub>pressure</sub>	D	H	G	t	b			
[N]	[mm]		[N]	[mm]		[mm]	[mm]		[mm]	[mm]			
35	5,0	10	120	1,0	120	15	15	M4	4,0	1,0	5218 060	45 NR 11	90767 •
80	6,0	10	240	1,0	240	15	15	M4	4,0	1,0	5218 060	60 NR 11	90617 •
80	4,2	20	180	1,0	180	20	20	M6	5,8	1,5	5218 053	45 NR 11	97163 •
200	4,2	50	350	1,0	350	20	20	M6	5,8	1,5	5218 053	60 NR 11	97162 •
65	9,0	10	75	2,3	30	20	25	M6	5,8	1,5	5218 097	45 NR 11	91741 •
140	11,0	10	160	2,4	70	20	25	M6	5,8	1,5	5218 097	60 NR 11	91063 •
220	9,0	20	240	1,8	130	25	20	M6	5,8	1,5	5218 088	60 NR 11	90648 •
300	6,0	50	380	1,1	350	30	25	M8	7,4	2,0	5218 165	60 NR 11	91028 •
160	7,5	20	360	2,4	150	30	30	M8	7,4	2,0	5218 069	45 NR 11	91161 •
370	7,5	50	760	2,4	320	30	30	M8	7,4	2,0	5218 069	60 NR 11	91062 •
400	5,0	80	700	1,5	470	40	30	M8	7,9	2,5	5218 021	60 NR 11	91273 •
670	5,0	130	1420	1,2	1180	40	30	M10	10,0	2,5	5218 002	60 NR 11	90565 •
880	5,0	180	2100	1,2	1750	40	30	M10	10,0	2,5	5218 002	70 NR 11	91112 •
200	12,0	20	370	3,5	110	40	40	M8	7,9	2,5	5218 043	45 NR 11	92282 •
550	12,0	50	900	3,5	260	40	40	M8	7,9	2,5	5218 043	60 NR 11	90596 •
450	10,0	50	700	3,0	230	50	30	M10	10,0	2,5	5218 091	45 NR 11	92163 •
900	11,0	80	1300	2,7	480	50	30	M10	10,0	2,5	5218 091	60 NR 11	91074 •
470	10,1	50	750	3,1	240	50	40	M10	10,0	2,5	5218 074	45 NR 11	91110 •
870	10,1	90	1440	3,1	460	50	40	M10	10,0	2,5	5218 074	60 NR 11	91236 •
1300	10,1	130	2110	3,1	680	50	40	M10	10,0	2,5	5218 074	70 NR 11	91197 •
450	17,0	30	550	4,8	110	50	45	M10	10,0	2,5	5218 176	45 NR 11	91402 •
450	19,0	20	500	5,4	90	50	50	M10	10,0	2,5	5218 112	45 NR 11	91412 •
900	20,0	50	1000	4,5	220	50	50	M10	10,0	2,5	5218 112	60 NR 11	91037 •
1300	18,0	70	1600	4,5	360	60	45	M10	10,0	2,5	5218 275	60 NR 11	93159 •
1800	18,0	100	2400	4,5	530	70	45	M10	10,5	3,0	5218 207	60 NR 11	90772 •
1500	19,0	80	2500	5,5	450	70	60	M12	10,5	3,0	5218 077	60 NR 11	90640 •
1000	14,0	70	1800	4,1	440	75	40	M12	10,5	3,0	5218 198	45 NR 11	97233 •
2100	16,0	130	3000	3,7	810	75	40	M12	10,5	3,0	5218 198	60 NR 11	97230 •
4000	15,0	270	6000	4,1	1460	75	40	M12	10,5	3,0	5218 198	75 NR 11	97229 •
5000	15,0	330	7000	3,6	1940	75	40	M12	10,5	3,0	5218 198	80 NR 11	97234 •
2100	20,0	110	2400	4,8	500	75	50	M12	10,5	3,0	5218 082	60 NR 11	90643 •
2050	14,0	150	4900	4,4	1110	75	50	M12	10,5	3,0	5218 082	70 NR 11	91460 •
2100	22,0	100	2400	5,3	450	75	55	M12	10,5	3,0	5218 212	60 NR 11	91045 •
3200	21	150	4000	5,5	730	75	55	M12	10,5	3,0	5218 212	70 NR 11	92517 •
2100	27	80	2000	6,5	310	75	70	M12	3	10,5	5218 115	60 NR 11	90667 •

● Available from stock ○ On request: Tool is available, delivery at short notice



Nominal maxima		Stiffness	Nominal maxima		Stiffness	Out-side Ø	Height	Threads	Screw-in depth max.	Sheet thickness	Product No.	Material	Article No.	
Radial shear			Axial pressure			D	H	G	t	b				
F <sub>S max</sub>	s <sub>S max</sub>	c <sub>shear</sub>	F <sub>S max</sub>	s <sub>S max</sub>	c <sub>pressure</sub>						[mm]	[mm]	[mm]	[mm]
[N]	[mm]		[N]	[mm]		[mm]	[mm]		[mm]	[mm]				
2000	20	100	3000	5,6	540	100	55	M16	15,8	4	5218 102	45 NR 11	91611	•
3800	21	180	5000	5,4	930	100	55	M16	15,8	4	5218 102	60 NR 11	90975	•
7000	25	280	9000	5,4	1670	100	55	M16	15,8	4	5218 102	70 NR 11	91522	•
1600	21	80	2700	6,5	420	100	75	M16	15,8	4	5218 049	45 NR 11	90602	•
2250	21	110	4100	6,5	630	100	75	M16	15,8	4	5218 049	60 NR 11	90603	•
5000	28	180	9000	8,0	1130	160	75	M16	15,8	4	5218 146	45 NR 11	90684	•
10000	32	310	15000	8,0	1880	160	75	M16	15,8	4	5218 146	60 NR 11	91431	•
8000	25	320	18000	6,9	2610	200	70	M16	15,8	6	5218 162	45 NR 11	92531	•
16000	26	620	36000	7,0	5140	200	70	M16	15,8	6	5218 162	60 NR 11	90618	•

● Available from stock    ○ On request: Tool is available, delivery at short notice

**Article list Circular Mount Type C with cylindrical elastomer contour**

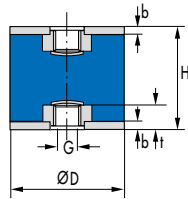
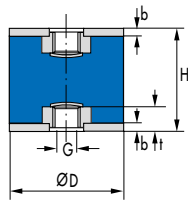

Fig. 13 Circular Mounts Type C, cylindrical elastomer contour

Nominal maxima				Outside Ø	Height	Threads	Screw-in depth (max.)	Thick-ness	Product No.	Material	Article No.	
Radial shear		Axial pressure										
F <sub>S max</sub>	s <sub>S max</sub>	F <sub>D max</sub>	s <sub>D max</sub>	D	H	G	t	b				
[N]	[mm]	[N]	[mm]	[mm]	[mm]		[mm]	[mm]				
32,8	2,9	57	0,8	16	15	M5	3	1,5	C 1615	55 NR	509219	•
32,8	3,7	51	1,1	16	20	M5	3	1,5	C 1620	55 NR	509220	•
51,2	1,9	48	1,5	16	25	M5	3	1,5	C 1625	55 NR	509221	•
51,2	3,5	102	0,7	20	15	M6	4	2,0	C 2015	55 NR	509222	•
51,2	4,4	86	1,1	20	20	M6	4	2,0	C 2020	55 NR	509223	•
51,2	0,8	79	1,4	20	25	M6	4	2,0	C 2025	55 NR	509224	•
51,2	0,7	76	1,7	20	30	M6	5	2,0	C 2030	55 NR	509225	•
79,8	3,0	148	1,1	25	20	M8	6	2,0	C 2520	55 NR	509226	•
79,8	3,5	141	1,2	25	22	M8	6	2,0	C 2522	55 NR	509227	•
79,8	4,4	133	1,4	25	25	M8	6	2,0	C 2525	55 NR	509228	•
79,8	6,1	124	1,8	25	30	M8	6	2,0	C 2530	55 NR	509229	•
115,1	1,9	115	2,4	25	40	M8	6	2,0	C 2540	55 NR	509230	•
115,1	4,4	219	1,2	30	22	M8	6	2,0	C 3022	55 NR	509231	•
115,1	6,5	189	1,8	30	30	M8	6	2,0	C 3030	55 NR	509232	•
204,1	2,7	173	2,4	30	40	M8	6	2,0	C 3040	55 NR	509233	•
204,1	6,1	390	1,6	40	28	M10	8	2,0	C 4028	55 NR	509234	•
204,1	6,1	376	1,8	40	30	M10	8	2,0	C 4030	55 NR	509235	•
204,0	6,9	350	2,9	40	35	M10	8	2,0	C 4035	55 NR	509236	•
204,0	4,4	332	2,4	40	40	M10	8	2,0	C 4040	55 NR	509237	•
319,0	2,5	320	2,8	40	45	M10	8	2,0	C 4045	55 NR	509238	•
319,2	5,0	671	1,7	50	30	M10	8	2,5	C 5030	55 NR	509239	•
319,0	5,9	609	2,0	50	35	M10	8	2,5	C 5035	55 NR	509240	•
319,0	6,7	569	2,4	50	40	M10	8	2,5	C 5040	55 NR	509241	•
319,0	7,5	540	2,7	50	45	M10	8	2,5	C 5045	55 NR	509242	•
459,0	3,7	519	3,0	50	50	M10	8	2,5	C 5050	55 NR	509243	•
459,0	6,7	948	2,1	60	36	M10	8	2,5	C 6036	55 NR	509244	•
626,0	4,9	836	2,7	60	45	M10	8	2,5	C 6045	55 NR	509245	•
626,0	7,4	1478	2,0	70	35	M10	9	3,0	C 7035	55 NR	509246	•
626,0	10,8	1169	3,0	70	50	M10	9	3,0	C 7050	55 NR	509247	•
718,0	3,2	1012,2	4,3	70	70	M10	9	3,0	C 7070	55 NR	509248	•
718,0	7,4	1600	2,3	75	40	M12	9	3,0	C 7540	55 NR	509249	•
718,0	8,2	1386	3,0	75	50	M12	9	3,0	C 7550	55 NR	509261	•
855,0	9,8	1591	4,0	75	55	M12	9	3,0	C 7555	55 NR	509262	•
817,0	10,8	1897	2,3	80	40	M14	12	3,0	C 8040	55 NR	509263	•
973,0	13,4	1620	5,4	80	70	M14	12	3,0	C 8070	55 NR	509265	•
973	14,8	1647	6,2	80	80	M14	12	3,0	C 8080	55 NR	509266	•
1278	8,2	3336	2,4	100	40	M16	14	3,0	C 10040	55 NR	509267	•

● Available from stock    ○ On request: Tool is available, delivery at short notice





Nominal maxima				Outside Ø	Height	Threads	Screw-in depth (max.)	Thick-ness	Product No.	Material	Article No.	
Radial shear		Axial pressure										
F <sub>S max</sub>	s <sub>S max</sub>	F <sub>D max</sub>	s <sub>D max</sub>	D	H	G	i	b				
[N]	[mm]	[N]	[mm]	[mm]	[mm]		[mm]	[mm]				
1521	9,8	3231	3,9	100	55	M16	14	3,0	C 10055	55 NR	509268	•
1521	10,8	3060	4,3	100	60	M16	14	3,0	C 10060	55 NR	509269	•
1521	13,8	2725	5,5	100	75	M16	14	3,0	C 10075	55 NR	509271	•
1521	14,8	2649	5,9	100	80	M16	14	3,0	C 10080	55 NR	509272	•
1520	18,8	2440	7,5	100	100	M16	14	3,0	C 100100	55 NR	509273	•

- Available from stock
- On request: Tool is available, delivery at short notice

# Buffer

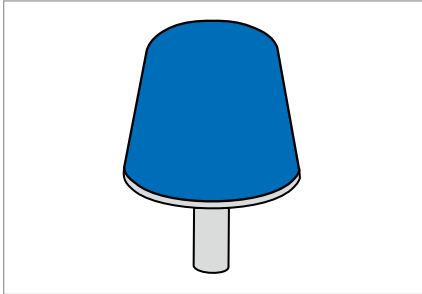

Fig. 1 Buffer

## Material

Standard material	Hardness
Natural rubber	40, 45, 50, 55, 60, 70 Shore A

## Operating conditions

Axial forces	37 N ... 18300 N	Maximum permissible force
Max. temperature	+60 °C, transient +80 °C	
Min. temperature	-45 °C	

## Product description

Buffers feature a very robust design. The wide selection of sizes allows for a universal use.

## Product advantages

- Effective buffering and damping of shock loads
- Easily installed
- RoHS-compliant.

## Application

Buffers are particularly suited as resilient deflection limiters and for buffering shock loads with mobile and non mobile driven machinery, machines and as stops in general.

Buffers with constricted body contour are specifically designed for high dynamic loads. The cone-shaped buffer design (observed in the longitudinal section) achieves a "softer" transient of the characteristic curve compared to cylindrical designs. The constricted design for circular buffers leads to significantly higher service life with otherwise equal deflection. Circular buffers that contact a flat surface can generate noise on impact. Cone buffers dramatically reduce these noise levels.

## Design notes

The buffers consist of an elastomer body with an end face to which a metal plate with threaded stud/nut is vulcanised. The elastomer body is available in cone-shaped, in cylindrical form as well as with constricted-body elastomer contour.

## Fitting & installation

- Buffers are designed to be secured by means of threaded fasteners
- Ensure that the metal plate is in full-surface contact with the mating face
- It is important to ensure that the mating face of the frame and the stop flat of the buffered mass are flat and smooth
- The form of the boreholes to accommodate the threaded studs must be compliant with DIN EN 20273
- Align the centreline of the buffer coaxially with the direction of impact
- Do not permit torque to act through the rubber element.

**Article List Circular Buffer with constricted-body elastomer contour**

Fig. 2 Circular Buffer, constricted-body elastomer contour

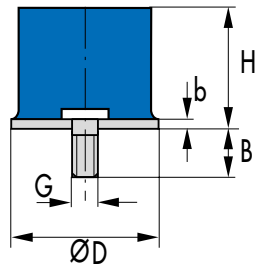
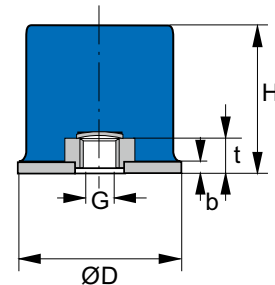
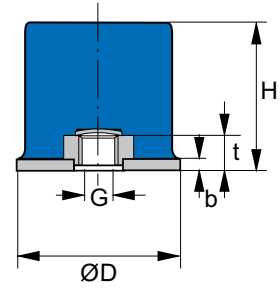
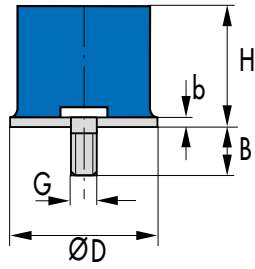

Fig. 3 Circular Buffer, constricted-body elastomer contour and nut



Nominal maxima		Stiffness	Metal sheet Ø	Total height	Threads	Length	Screw-in depth max.	Sheet thickness	Product No.	Material	Remark	Article No.	
Axial pressure			D	H	G	B	t	b					
F <sub>D max</sub>	s <sub>D max</sub>	c <sub>D</sub>											
140	0,6	230	15	6,0	M 4	15,0	-	1,2	030 18 068	60 NR 11	Screw (A)	90496	•
65	1,2	50	15	13,0	M 4	15,0	-	1,0	030 18 029	60 NR 11	Screw (A)	91040	•
65	1,2	50	15	13,0	M 4	-	3,8	1,0	030 18 030	60 NR 11	Nut (C)	90310	•
320	0,5	640	16	4,0	M 4	10,0	-	1,0	030 18 027	60 NR 11	Screw (A)	90308	•
270	1,2	230	20	12,0	M 6	10,5	-	1,5	030 18 055	70 NR 11	Screw (A)	91589	•
175	1,2	150	20	12,0	M 6	10,5	-	1,5	030 18 055	60 NR 11	Screw (A)	90335	•
180	1,5	120	20	16,0	M 6	18,5	-	1,5	030 18 031	80 NR 11	Screw (A)	97156	•
120	1,5	80	20	16,0	M 6	18,5	-	1,5	030 18 031	60 NR 11	Screw (A)	97155	•
120	1,5	80	20	16,0	M 6	-	6,5	1,5	030 18 032	60 NR 11	Nut (C)	97160	•
60	1,5	40	20	16,0	M 6	18,5	-	1,5	030 18 031	45 NR 11	Screw (A)	97159	•
720	2,2	330	30	16,0	M 8	23,0	-	2,0	030 18 035	60 NR 11	Screw (A)	597193	•
380	1,5	250	30	16,0	M 8	20,0	-	2,0	030 18 094	60 NR 11	Screw (A)	97196	•
380	1,5	250	30	16,0	M 8	13,0	-	2,0	030 18 095	60 NR 11	Screw (A)	97197	•
310	2,0	160	30	18,0	M 8	23,0	-	2,0	030 18 133	60 NR 11	Screw (A)	97198	•
175	2,0	90	30	18,0	M 8	-	6,9	2,0	030 18 161	40 NR 11	Nut (C)	597200	•
600	4,0	150	30	26,0	M 8	23,0	-	2,0	030 18 037	60 NR 11	Screw (A)	90317	•
1000	3,1	330	40	26,0	M10	27,5	-	2,5	030 18 039	60 NR 11	Screw (A)	91070	•
800	3,0	270	40	30,0	M 8	22,5	-	2,5	030 18 120	60 NR 11	Screw (A) slightly tapered	90358	•
1200	4,0	300	40	30,0	M10	27,5	-	2,5	030 18 023	60 NR 11	Screw (A)	90305	•
600	1,5	400	40	30,0	M10	-	8,5	2,5	030 18 099	60 NR 11	Nut (C) slightly tapered	93047	•
620	3,0	210	40	30,0	M 8	-	6,9	2,5	030 18 162	60 NR 11	Nut (C)	90379	•
3200	1,3	2560	50	12,0	M10	27,5	-	2,5	030 18 026	60 NR 11	Screw (A)	90307	•
1700	4,1	420	50	36,0	M10	27,5	-	2,5	030 18 041	60 NR 11	Screw (A)	90321	•
1500	4,5	330	50	37,5	M10	27,5	-	2,5	030 18 054	60 NR 11	Screw (A)	500068	•
2800	7,6	370	70	55,0	M12	37,0	-	3,0	030 18 043	60 NR 11	Screw (A)	90324	•
5100	2,0	2550	75	20	M12	37	-	3	030 18 045	60 NR 11	Screw (A)	597219	•
5100	2,0	2550	75	20	M12	-	9,5	3	030 18 046	60 NR 11	Nut (C)	97221	•
5000	3,0	1670	75	30	M12	-	9,5	3	030 18 164	70 NR 11	Nut (C)	500194	•
4800	4,1	1170	75	30	M12	37	-	3	030 18 137	60 NR 11	Screw (A)	90362	•
3200	3,0	1070	75	30	M12	-	9,5	3	030 18 164	60 NR 11	Nut (C)	90381	•
4100	2,7	1520	75	45	M12	-	9,5	3	030 18 048	70 NR 11	Nut (C)	90327	•
4300	6,6	650	75	45	M12	37	-	3	030 18 047	60 NR 11	Screw (A)	91616	•

• Available from stock    ○ On request: Tool is available, delivery at short notice



Nominal maxima		Stiffness	Metal sheet Ø	Total height	Threads	Length	Screw-in depth max.	Sheet thickness	Product No.	Material	Remark	Article No.	
Axial pressure			D	H	G	B	t	b					
F <sub>D max</sub>	s <sub>D max</sub>	c <sub>D</sub>							[N]	[mm]	[N/mm]	[mm]	[mm]
2600	2,7	960	75	45	M12	-	9,5	3	030 18 048	60 NR 11	Nut (C)	91537	•
1300	2,7	480	75	45	M12	-	9,5	3	030 18 048	45 NR 11	Nut (C)	92047	•
6450	7,0	920	100	69	M16	-	15,0	4	030 18 050	70 NR 11	Nut (C)	91773	○
18300	8,3	2200	160	65	M16	46	-	4	030 18 165	60 NR 11	Screw (A)	91253	•
8100	6,0	1350	160	65	M16	-	15,0	4	030 18 166	60 NR 11	Nut (C)	91265	•
12500	6,0	2080	160	65	M16	-	15,0	4	030 18 166	50 NR 11	Nut (C)	95139	•

• Available from stock    ○ On request: Tool is available, delivery at short notice

**Article list Circular Buffer with cylindrical elastomer contour**

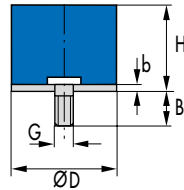
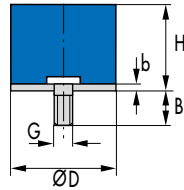

Fig. 4 Circular Buffer, cylindrical elastomer contour

Nominal maxima				Outside Ø	Height	Threads	Length	Thick-ness	Product No.	Material	Article No.	
Axial pressure		Radial shear										
F <sub>D max</sub>	s <sub>D max</sub>	F <sub>S max</sub>	s <sub>S max</sub>	D	H	G	B	b				
[N]	[mm]	[N]	[mm]	[mm]	[mm]		[mm]	[mm]				
46	0,7	26	1,8	13	10	M5	10,0	1,0	D 1310	55 NR	509157	•
41	1,0	26	2,5	13	13,5	M5	10,0	1,0	D 1313	55 NR	509158	•
41	1,2	26	2,8	13	15	M5	10,0	1,0	D 1315	55 NR	509159	•
37	1,5	26	3,8	13	20	M5	10,0	1,0	D 1320	55 NR	509160	•
198	1,7	39	1,7	16	10	M5	12,0	1,5	D 1610	55 NR	509161	•
65	1,1	39	2,7	16	15	M5	12,0	1,5	D 1615	55 NR	509164	•
59	1,5	39	3,7	16	20	M5	12,0	1,5	D 1620	55 NR	509165	•
59	2,0	39	4,7	16	25	M5	12,0	1,5	D 1625	55 NR	509166	•
172	0,5	61	1,3	20	8,5	M6	16,5	2,0	D 208,5	55 NR	509167	•
112	1,0	61	2,6	20	15	M6	16,5	2,0	D 2015	55 NR	509168	•
99	1,4	61	3,6	20	20	M6	16,5	2,0	D 2020	55 NR	509169	•
92	1,8	61	4,6	20	25	M6	16,5	2,0	D 2025	55 NR	509170	•
92	2,3	61	5,6	20	30	M6	16,5	2,0	D 2030	55 NR	509171	•
273	0,6	95	1,6	25	10	M8	20,0	2,0	D 2510	55 NR	509172	•
273	0,6	95	1,6	25	15	M8	20,0	2,0	D 2515	55 NR	509173	•
171	1,4	95	3,4	25	19	M8	20,0	2,0	D 2519	55 NR	509174	•
161	1,6	95	4,0	25	22	M8	20,0	2,0	D 2522	55 NR	509176	•
161	1,9	95	4,6	25	25	M8	20,0	2,0	D 2525	55 NR	509177	•
145	2,2	95	5,6	25	30	M8	20,0	2,0	D 2530	55 NR	509178	•
136	3,0	95	7,6	25	40	M8	20,0	2,0	D 2540	55 NR	509179	•
287	1,2	137	3,0	30	15	M8	25,0	2,0	D 3015	55 NR	509180	•
249	1,6	137	4,0	30	22	M8	25,0	2,0	D 3022	55 NR	509181	•
220	2,2	137	5,6	30	30	M8	25,0	2,0	D 3030	55 NR	509182	•
203	3,0	137	7,6	30	40	M8	25,0	2,0	D 3040	55 NR	509183	•
544	1,4	243	3,6	40	20	M10	25,0	2,0	D 4020	55 NR	509184	•
474	1,8	243	4,6	40	25	M10	25,0	2,0	D 4025	55 NR	509185	•
407	2,6	243	6,6	40	35	M10	25,0	2,0	D 4035	55 NR	509186	•
407	3,2	243	7,6	40	40	M10	25,0	2,0	D 4040	55 NR	509187	•
376	3,5	243	8,6	40	45	M10	25,0	2,0	D 4045	55 NR	509188	•
850	1,8	380	4,5	50	25	M10	25,0	2,5	D 5025	55 NR	509189	•
699	2,6	380	6,5	50	35	M10	25,0	2,5	D 5035	55 NR	509190	•
630	3,4	380	8,5	50	45	M10	25,0	2,5	D 5045	55 NR	509191	•
1551	1,6	547	3,9	60	22	M10	25,0	2,5	D 6022	55 NR	509193	•
1385	1,8	547	4,5	60	25	M10	25,0	2,5	D 6025	55 NR	509194	•
1083	2,7	547	6,7	60	36	M10	25,0	2,5	D 6036	55 NR	509195	•
971	3,4	547	8,5	60	45	M10	25	2,5	D 6045	55 NR	509196	•
1650	2,6	745	6,4	70	35	M10	25	3,0	D 7035	55 NR	509197	•
1351	3,8	745	9,4	70	50	M10	25	3,0	D 7050	55 NR	509198	•

• Available from stock    ○ On request: Tool is available, delivery at short notice

Elastomer Dampers



Nominal maxima				Outside Ø	Height	Threads	Length	Thick-ness	Product No.	Material	Article No.	
Axial pressure		Radial shear										
F <sub>D max</sub>	s <sub>D max</sub>	F <sub>S max</sub>	s <sub>S max</sub>	D	H	G	B	b				
[N]	[mm]	[N]	[mm]	[mm]	[mm]		[mm]	[mm]				
1351	3,8	745	9,4	70	70	M10	25	3,0	D 7070	55 NR	509199	•
3195	1,8	973	4,4	80	25	M14	35	3,0	D 8025	55 NR	509201	•
2674	2,2	973	5,4	80	30	M14	35	3,0	D 8030	55 NR	509203	•
2140	3,0	973	7,4	80	40	M14	35	3,0	D 8040	55 NR	509204	•
1620	5,4	973	13,4	80	70	M14	35	3,0	D 8070	55 NR	509205	•
1620	6,4	973	15,4	80	80	M14	35	3,0	D 8080	55 NR	509206	•

● Available from stock    ○ On request: Tool is available, delivery at short notice

### Article list Cone Buffers

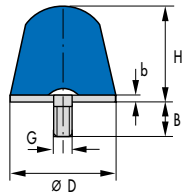

Fig. 5 Cone Buffer

Nominal maxima			Stiffness	Ø	Height	Threads	Length	Thickness	Product No.	Material	Article No.	
Axial pressure												
F <sub>max</sub>	s <sub>max</sub>	c <sub>pressure</sub>	D	H	G	B	b					
[N]	[mm]	[N/mm]	[mm]	[mm]		[mm]	[mm]					
400	1,5	270	26	18	M6	22	1,5	3018 131	60 NR 11	92544	•	
90	3,8	20	35	40	M8	23	2	3018 025	45 NR 11	49009020	•	
220	3,8	60	35	40	M8	23	2	3018 025	60 NR 11	90306	•	
320	3,8	80	35	40	M8	23	2	3018 025	70 NR 11	91311	•	
1900	3	630	50	21	M10	27,5	2,5	3018 061	60 NR 11	90337	•	
10000	20	500	125	78	M16	46	4	3018 158	60 NR 11	90376	•	

● Available from stock    ○ On request: Tool is available, delivery at short notice

## M Mount

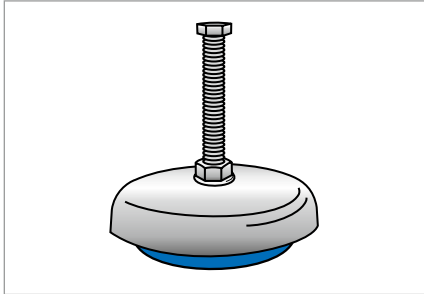

Fig. 1 M Mount

### Material

Standard material	Hardness
Acrylonitrile-butadiene rubber NBR 68	45, 55, 60, 65, 70, 75, 85 Shore A

### Operating conditions

Compressive forces in Z direction	1200 N ... 55000 N	Maximum permissible force
Max. temperature	+90 °C, transient +110 °C	
Min. temperature	-20 °C	

### Product description

M mounts combine a low-line compact design with good insulation capabilities and the possibility of levelling load.

### Product advantages

- Oil-resistant elastomer material
- Non-anchored installation
- Reduced transmission of structure-borne noise
- Good insulating capability
- Built-in capability for levelling the load
- RoHS-compliant.

### Application

M mounts are used for non-anchored installation and heavy driven machinery. They feature the capacity for levelling of the attached machine and provide vibration insulation.

## Material

Standard material	Hardness
Acrylonitrile-butadiene rubber NBR 68	45, 55, 60, 65, 70, 75, 85 Shore A

## Operating conditions

Compressive forces in Z direction	1200 N ... 55000 N	Maximum permissible force
Max. temperature	+90 °C, transient +110 °C	
Min. temperature	-20 °C	

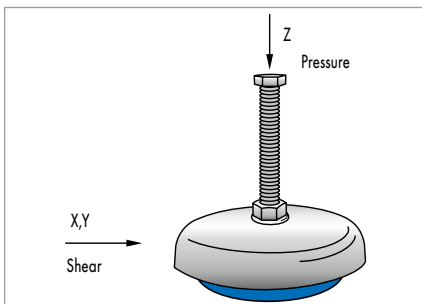

Fig. 2 Primary load directions

M mounts feature an increasing stiffness over the compressive deflection in the Z direction. Through no anchoring in the foundation or frame, no shear forces should be transferred. The weight is absorbed in the longitudinal axis. M mounts made from stainless steel and special rubber compounds can be supplied on enquiry for special application cases (e.g. food processing or chemical industries and shipbuilding).

## Design notes

The mounts consist of two metal parts that are joined by a vulcanised elastomer pad. An adjusting screw allows for levelling of the attached machine. The special mixture of nitrile-rubber (Perbunan) used for the M Mount is oil-resistant.

## Fitting & installation

- M mounts have an adjusting screw for securing them to the mass they carry, and are designed to sit on the supporting surface without being anchored
- Ensure that the mating face of the mass carried by the mount is parallel with the supporting surface, and make sure that the supporting surface is level and smooth
- The nut is for securing the leg of the machine to the mount
- This arrangement means that the weight of the machine does not impose a load on the nut in the bowl of the mount
- Do not under any circumstances attempt to sandwich the leg of the machine between two nuts
- The form of the boreholes to accommodate the threaded studs or securing screws must be compliant with DIN EN 20273
- It is important to ensure that the mating faces of the frame anchorage and the mass carried by the mount are flat and smooth
- M mounts can also be installed without threaded fasteners if compressive-load deflection is significantly greater than maximum amplitude.



Article list

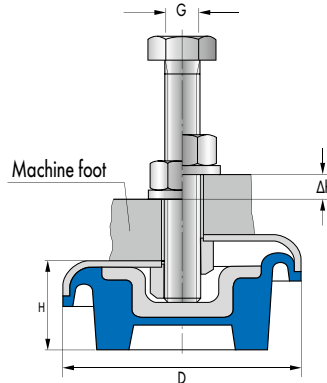

Fig. 3 M Mount

Nominal maxima		Stiffness	Outside Ø	Height	Adjustment height	Threads	Product No.	Material	Type	Article No.	
Pressure											
$F_z \text{ max}$	$s_z \text{ max}$	$c_z$	D	H	$\Delta h$	G					
[N]	[mm]	[N/mm]	[mm]	[mm]	[mm]						
1200	3,5	340	80	30	8	M 12 x 80	5018 023	45 NBR 68	M 80/1	96504	•
2000	3,5	570	80	30	8	M 12 x 80	5018 023	60 NBR 68	M 80/3	96505	•
3000	3,5	850	80	30	8	M 12 x 80	5018 023	70 NBR 68	M 80/4	96506	•
3500	3,5	1000	80	30	8	M 12 x 80	5018 023	75 NBR 68	M 80/5	96507	•
5000	4,0	1250	120	37	12	M 12 x 100	5018 020	45 NBR 68	M120/1	96496	•
6000	4,0	1500	120	37	12	M 12 x 100	5018 020	55 NBR 68	M120/2	96497	•
8000	4,0	2000	120	37	12	M 12 x 100	5018 020	65 NBR 68	M120/3	96498	•
9200	4,0	2300	160	41	12	M 16 x 120	5018 021	45 NBR 68	M160/1	96499	•
13500	4,0	3375	160	41	12	M 16 x 120	5018 021	65 NBR 68	M160/3	96500	•
18000	4,0	4500	160	41	12	M 16 x 120	5018 021	70 NBR 68	M160/4	96501	•
9200	4,0	2300	160	41	12	M 16 x 140	5018 704	45 NBR 68	M160/1	49039496	○
13500	4,0	3375	160	41	12	M 16 x 140	5018 704	65 NBR 68	M160/3	49039497	○
18000	4,0	4500	160	41	12	M 16 x 140	5018 704	70 NBR 68	M160/4	49014539	•
26000	4,0	6500	185	48	8	M 20 x 160	5018 022	75 NBR 68	M185/5	96502	•
55000	4,0	13750	185	48	8	M 20 x 160	5018 022	85 NBR 68	M185/6	96503	•

• Available from stock    ○ On request: Tool is available, delivery at short notice

# Instrument Mount

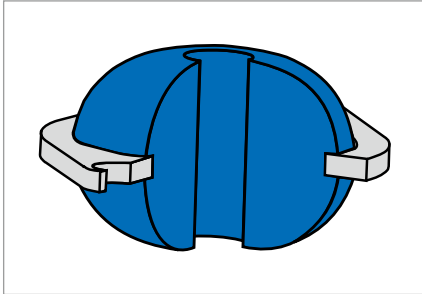

Fig. 1 Instrument Mount

## Material

Standard material	Hardness
Natural rubber	40, 50, 60 Shore A

## Operating conditions

<b>Axial forces</b>	80 N ... 260 N	Maximum permissible force
<b>Max. temperature</b>	+60 °C, transient +80 °C	
<b>Min. temperature</b>	-45 °C	

## Product description

The mounts protect sensitive instruments against impact and dynamic excitation.

## Product advantages

- Reduced transmission of structure-borne noise
- Compact
- Easily installed
- Uniform stiffness in the radial directions
- RoHS-compliant.

## Application

Instrument mounts are utilised for vibration insulation of electronic components, measuring devices and precise mechanical apparatuses and for instrument panels or control panels in industrial applications. A common requirement of these mounts is that they keep vibrations or shock loads introduced via the anchorages away from the instrument or device. The mounts help to protect sensitive instruments from external shock loads in mobile and non mobile use. Another possible use is insulation against structure-borne sound, for example in small electric engines or pumps that have to be mounted on "resonators" (sheet metal).

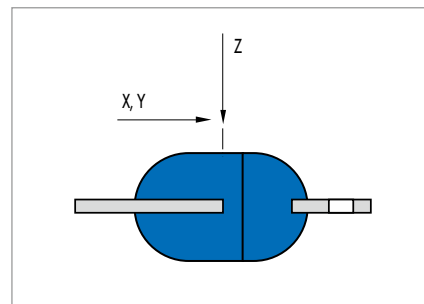

Fig. 2 Primary load directions

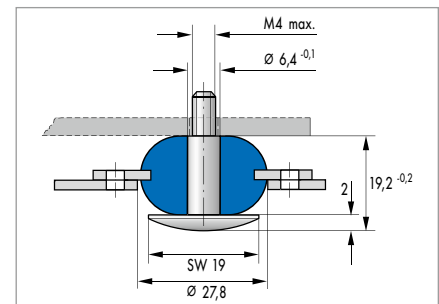

Fig. 3 Installation diagram with stud SW19

Instrument mounts are generally designed with the same stiffness in all translatory deformation directions. The limitation of the spring displacements in the radial direction generally appear more than in the axial direction. The static load of the weight should primarily be absorbed in the longitudinal axis.

## Design notes

The instrument mount comprises a carrier washer with connected or vulcanised elastomer body with central through-hole. Through-holes are attached outside in the flange of the carrier washer. A stiffening metal part can be vulcanised into the middle of the elastomer body.

## Fitting & installation

- Instrument mounts are designed to be anchored by threaded fasteners
- Slight, non-load-related, installation-related offset of the central securing screw relative to the flange is permissible. The same applies to slight angular offset
- Locate instrument mounts in line with the axis of the static primary load
- Make sure that the cut-out to be occupied by the elastomer body is free of burrs and at least 1/10 mm larger than the outside diameter of the elastomer part
- Allow for the requisite spring displacement when selecting the length of the central screw and sizing the cut-out to accommodate the mount
- When securing the flange use washers and make sure that a large, flat and smooth surface is available for force transfer from threaded fastener to elastomer part.

Article list

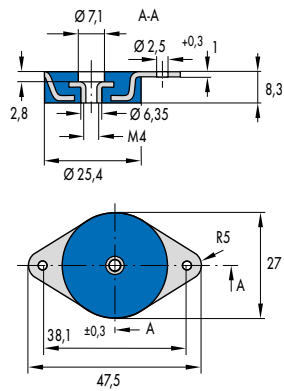

Fig. 4 Instrument Mount 039 18 022

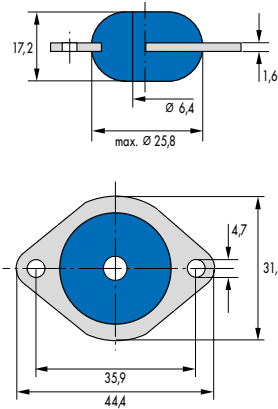

Fig. 5 Instrument Mount 039 18 023

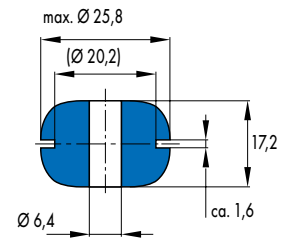

Fig. 6 Instrument Mount 039 18 751

Nominal maxima		Stiffness	Nominal maxima		Stiffness	Product No.	Material	Article No.	
Axial pressure			Radial shear						
$F_z$ max	$s_z$ max	$c_z$	$F_{xy}$ max	$s_{xy}$ max	$c_{xy}$				
[N]	[mm]	[N/mm]	[N]	[mm]	[N/mm]				
120	0,5	240	200	1	200	3918 022	40 NR 11	93657	•
80	2,0	40	45	2	20	3918 023	40 NR 11	93658	•
130	2,0	65	75	2	40	3918 023	50 NR 11	93659	•
260	2,0	130	130	2	70	3918 023	60 NR 11	93660	•
80	2,0	40	45	2	20	3918 751	40 NR 11	49039880	○
130	2,0	65	75	2	40	3918 751	50 NR 11	49039881	○
260	2,0	130	130	2	70	3918 751	60 NR 11	49039902	○

● Available from stock    ○ On request: Tool is available, delivery at short notice

## O-Shaped Mount

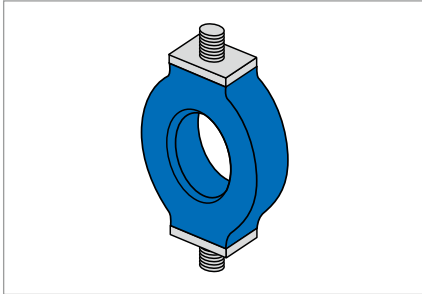

Fig. 1 O-Shaped Mount

### Product description

O-shaped mounts have a very soft spring characteristic and are therefore commonly referred to as low-frequency mounts.

### Product advantages

- Reduced transmission of structure-borne noise
- Compact
- Deformable in various planes
- Easily installed
- RoHS-compliant.

### Application

O-shaped mounts are of a design that enables good vibration insulation for the loads that typically occur in instrumentation and control applications.

### Material

Standard material	Hardness
Natural rubber	40, 45, 60 Shore A
Acrylonitrile-butadiene rubber NBR 68	60 Shore A
Ethylene-propylene rubber EPDM 22	60 Shore A

### Operating conditions

<b>Axial forces</b>	20 N ... 215 N	Maximum permissible force
<b>Max. temperature</b>	up to +60 °C transient up to +80 °C for NR	
<b>Min. temperature</b>	-45 °C for NR	

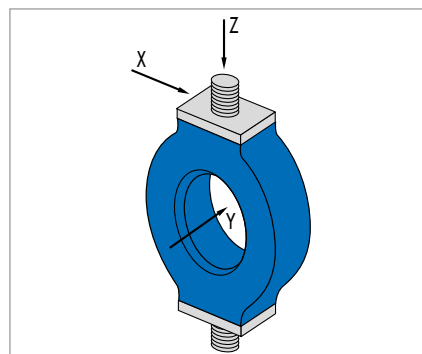

Fig. 2 Primary load directions

The spring characteristic of the O-shaped mount increases in the order X, Y and Z, whereby depending on the orientation, an optimal vibration insulation can be achieved. The primary load direction is the longitudinal axis of the threaded studs (Z direction).

**Design notes**

The component consists of a ring-shaped elastomer body with each flat vulcanised to securing plates with screws.

**Fitting & installation**

- Individual components permit slight adjustment to allow for in-situ offset
- The form of the boreholes to accommodate the threaded studs must be compliant with DIN EN 20273
- The securing plates must be in full-surface contact with the mating faces.

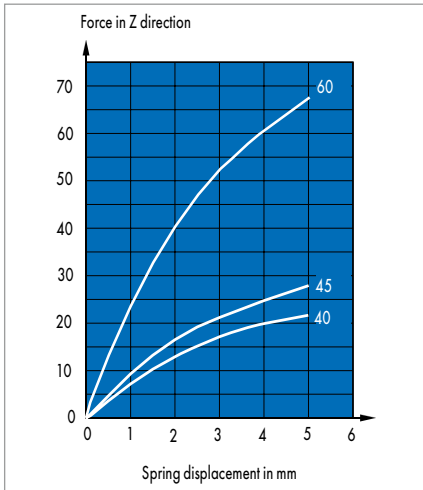

Fig. 3 Spring characteristic  
O-Shaped Mount 055 18 001

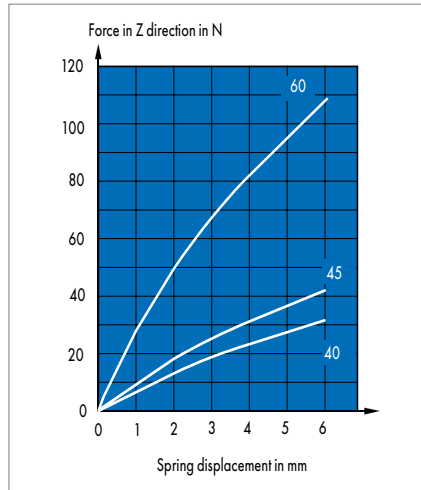

Fig. 4 Spring characteristic  
O-Shaped Mount 055 18 002

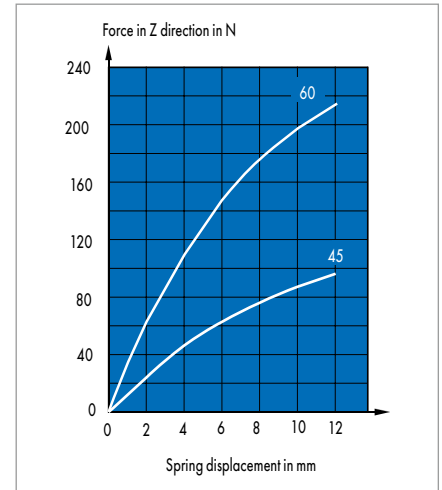

Fig. 5 Spring characteristic  
O-Shaped Mount 055 18 003

Article list

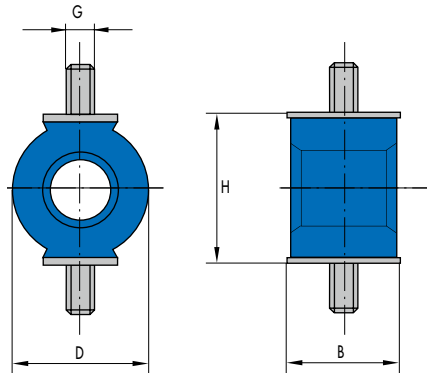

Fig. 6 O-Shaped Mount

Nominal maxima			Stiffness	Nominal maxima			Stiffness			Nominal maxima	Stiffness	Width	Length	Height	Threads	Product No.	Material	Article No.	
Axial pressure			Radial shear			Radial shear			B	D	H	G							
F <sub>z max</sub>	s <sub>z max</sub>	c <sub>z</sub>	F <sub>x max</sub>	s <sub>x max</sub>	c <sub>x</sub>	F <sub>y max</sub>	s <sub>y max</sub>	c <sub>y</sub>											
[N]	[mm]	[N/mm]	[N]	[mm]	[N/mm]	[N]	[mm]	[N/mm]	[mm]	[mm]	[mm]	[mm]							
20	4	5,0	4,5	4	1,1	9,5	4	2,4	15	14	18	M 4 X 7	5518 001	40 NR 11	96740	•			
25	4	6,3	6,0	4	1,5	12,0	4	3,0	15	14	18	M 4 X 7	5518 001	45 NR 11	96741	○			
60	4	15,0	14,5	4	3,6	28,0	4	7,0	15	14	18	M 4 X 7	5518 001	60 EPDM 22	49023643	•			
60	4	15,0	14,5	4	3,6	28,0	4	7,0	15	14	18	M 4 X 7	5518 001	60 NBR 68	49023642	•			
60	4	15,0	14,5	4	3,6	28,0	4	7,0	15	14	18	M 4 X 7	5518 001	60 NR 11	96761	•			
32	6	5,3	13,0	8	1,6	20,0	8	2,5	22	25	30	M 5 X 10	5518 002	40 NR 11	96757	•			
40	6	6,7	17,0	8	2,1	25,0	8	3,1	22	25	30	M 5 X 10	5518 002	45 NR 11	96755	•			
110	6	18,3	35,0	8	4,4	70,0	8	8,8	22	25	30	M 5 X 10	5518 002	60 NR 11	96742	•			
95	12	7,9	27,0	10	2,7	50,0	10	5,0	28	36	38	M 6 X 9,5	5518 003	45 NR 11	96743	•			
215	12	17,9	55,0	10	5,5	110,0	10	11,0	28	36	38	M 6 X 9,5	5518 003	60 NR 11	96750	•			
215	12	17,9	55,0	10	5,5	110,0	10	11,0	28	36	38	M 6 X 9,5/18	5518 023	60 NR 11	90150	•			
215	12	17,9	55,0	10	5,5	110,0	10	11,0	28	36	38	M 6 X 15	5518 700	60 NR 11	500640	•			
215	12	17,9	55,0	10	5,5	110,0	10	11,0	28	36	38	M 6 X 15	5518 700	60 EPDM 22	49002215	•			
110	6	18,3	35,0	8	4,4	70,0	8	8,8	22	25	30	M 5 X 10	5518 703	60 EPDM 22	477967	○			

• Available from stock    ○ On request: Tool is available, delivery at short notice

## Top Mount

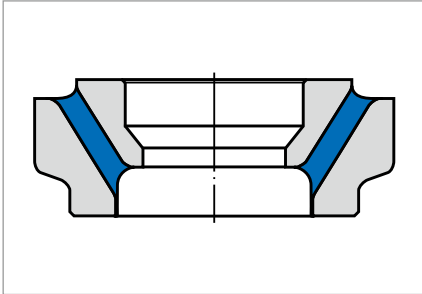

Fig. 1 Top Mount

### Material

Standard material	Hardness
Natural rubber	50, 60, 70 Shore A

### Operating conditions

Transverse forces in Z direction	10500 N ... 25300 N	Maximum permissible force
Max. temperature	+60 °C, transient +80 °C	
Min. temperature	-45 °C	

### Product description

Top mounts can permit radial, axial and angular movements.

### Product advantages

- Good insulating capability in the Z direction
- Easily installed
- Spacing can be varied to suit the application
- RoHS-compliant.

### Application

Top mounts are particularly suitable for connecting a dynamically loaded sub-assembly such as an engine or gearbox to a fixed assembly such as a frame.

## Material

Standard material	Hardness
Natural rubber	50, 60, 70 Shore A

## Operating conditions

Transverse forces in Z direction	10500 N ... 25300 N	Maximum permissible force
Max. temperature	+60 °C, transient +80 °C	
Min. temperature	-45 °C	

The mount configurations feature the same stiffness in the radial directions (X and Y direction). The ratio of stiffness in the radial direction and in the axial direction varies in considerable dependence to the tapered angle. Top mounts are designed for primary loading in the radial as well as axial directions. They are designed for pairwise use, aligned facing each other with defined axial pre-loading. Support mounts can permit and limit radial, axial and angular movements. The primary load direction should be absorbed in the longitudinal axis or perpendicular to it.

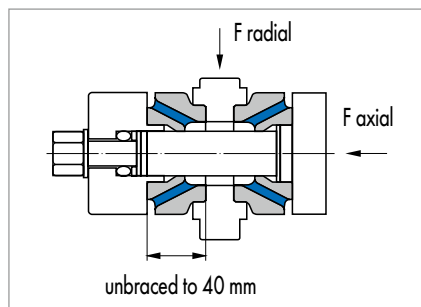

Fig. 2 Fitting & installation instructions:  
Top Mount with load directions

## Design notes

A top mount consists of two tapering tubular components held together by a rubber layer.

## Fitting & installation

- Top mounts are designed to be secured by means of fits
- Individual components permit slight adjustment to allow for in-situ offset
- Always install top mounts centred and at right angles to the axis of primary radial loading and utilise the entire cylindrical surface area on both the inside and the outside as the bearing surfaces
- Position the mounts in counteracting pairs, positioned in such a way that the inner and outer metal parts of the top mounts are preloaded relative to each other
- The elasticity of the material permits offset to be compensated in all directions.



**Article list**

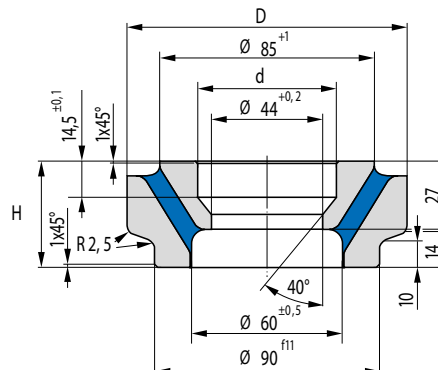

Fig. 3 Top Mount O40 18 876

Nominal maxima		Stiffness		D	d	H	Tol.	Product No.	Material	Article No.	
Radial shear		Axial pressure	Radial shear								
$F_{r \max}$	$S_{r \max}$	$c_{axial}$	$c_{radial}$		Tol. H9						
		braced to H=20 mm	unbraced to H=40 mm			unbraced					
[N]	[mm]	[N/mm]	[N/mm]	[mm]	[mm]	[mm]					
10500	2,3	17000	17000	112	55	41,8	±0,3	40 18 876	45 NR 11	49026815	○
25390	2,3	22000	34800	112	55	41,8	±0,3	40 18 876	60 NR 11	49026816	○
40000	2,3	34000	55000	112	55	41,8	±0,3	40 18 876	70 NR 11	2129382	○

● Available from stock    ○ On request: Tool is available, delivery at short notice

# Spherical Roller Bearing

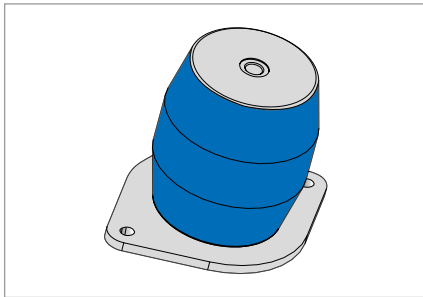

Fig. 1 Spherical Roller Bearing

## Product description

Spherical roller bearings are ideal for their vertical loading and insulation against low-amplitude vibrations.

## Product advantages

- Parallel fastening surfaces
- Installation with standard screws
- Prepared for heat dissipation
- Low proportion of metal
- RoHS-compliant.

## Application

Masses that experience or themselves cause minor vibration amplitudes according to deflection can be mounted on spherical roller bearings. This makes this mount configuration suitable for selected engines, compressors, units, mounting equipment and also heavy duty switch cabinets, control systems, stationary control panels, measurement equipment.

## Material

Standard material	Hardness
Natural rubber	45, 55, 65 Shore A

## Operating conditions

Axial forces	9000 N ... 20000 N
Max. temperature	60 °C, transient +80 °C
Min. temperature	-45 °C

Spherical roller bearings have different stiffness in axial and radial direction. In the axial direction the stiffness is many times that of the radial direction.

The primary load direction is recommended to be in the longitudinal axis and central to the installation area.

## Design notes

A key feature of the spherical roller bearings is the generally cylindrical to convex shape with central through-bore in the elastomer body. There is a metal plate with a central thread on one side on the front side, which is vulcanised to the elastomer body. On the opposite

front side there are several nuts vulcanised into the elastomer. The cylindrical to convex shape should be taken into account in the design of the consoles. This mount should only be used with axial preloading. Note that only small radial deflections are permitted.

## Fitting & installation

- Rubber mounts are designed to be fitted vertically by means of threaded fasteners
- A sufficient radial spacing to the console components is required
- The installation areas must be free of fluids. There must be no metal shavings or sharp edges in the vicinity of the installation areas
- It is beneficial to ventilate the central bore in the elastomer body
- Radial or angular offset of the fastening areas caused by installation should be prevented
- Uniform screw tightness is required.

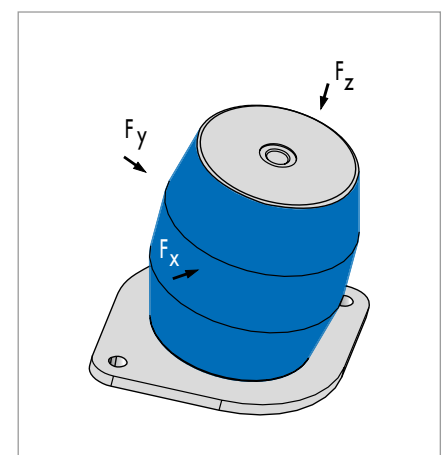

Fig. 2 Primary load direction

Article list

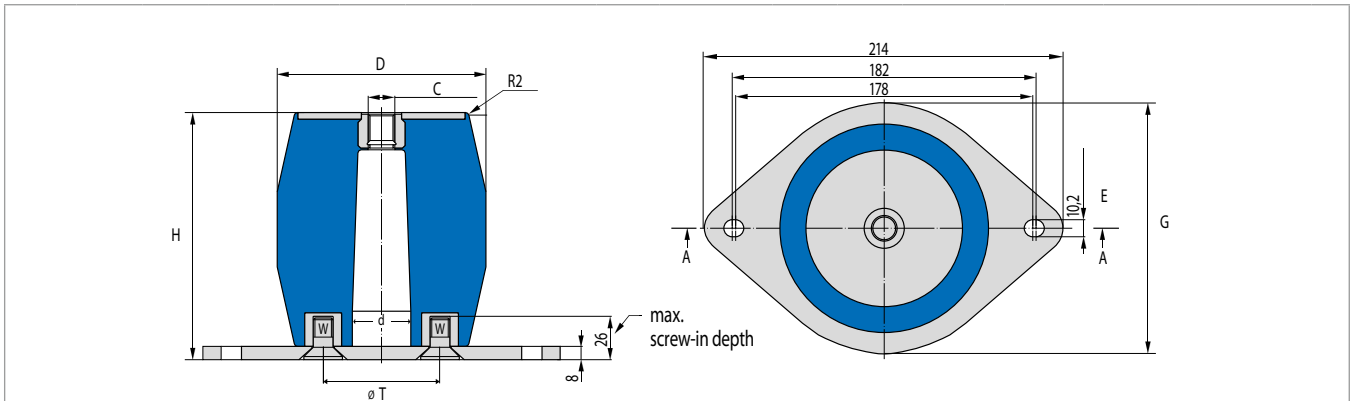

Fig. 3 Spherical Roller Bearing

Nominal maxima			Dimensions										Product No.	Material	with base plate	Article No.		
Axial pressure			D	d	H	ØT	P	C	W	L	G	E						
F <sub>z max</sub>	S <sub>z max</sub>	C <sub>z max</sub>	[mm]	[mm]	[mm]	[mm]	[mm]			[mm]	[mm]	[mm]						
[N]	[mm]	[N/mm]																
9000	50	180	125	35	142	70	26	M16	M12	178...182	150	10,2	3918 756	45 NR 11	mounted	49040133	○	
13800	50	280	125	35	142	70	26	M16	M12	178...182	150	10,2	3918 756	55 NR 11	mounted	49040134	○	
20000	50	400	125	35	142	70	26	M16	M12	178...182	150	10,2	3918 756	65 NR 11	mounted	49040135	○	
9000	50	180	125	35	150	70	18	M16	M12	-	-	-	3918 756	45 NR 11	without	49040061	○	
13800	50	280	125	35	150	70	18	M16	M12	-	-	-	3918 756	55 NR 11	without	49002648	○	
20000	50	400	125	35	150	70	18	M16	M12	-	-	-	3918 756	65 NR 11	without	49040132	○	

- Available from stock
- On request: Tool is available, delivery at short notice

## Layered Springs

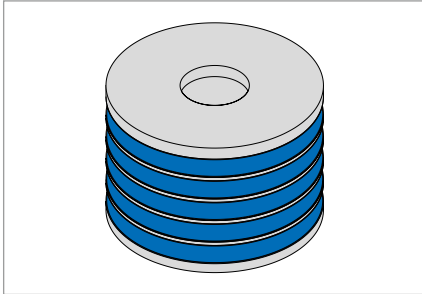

Fig. 1 Layered Springs

### Product description

Layered springs are specifically used for the decoupling of horizontal vibrations. These mounts remain very stiff at the same time.

### Product advantages

- Good insulating capability in the radial direction
- Compressively stiff in the axial direction
- Easily installed
- RoHS-compliant.

### Application

Layered springs are resilient mounts suitable for use as bearers for subassemblies such as engines or gearboxes.

### Material

Standard material	Hardness
Natural rubber	40, 50, 60, 70 Shore A
Natural rubber NR 39, 97	60 Shore A
Chloroprene rubber CR 57	60 Shore A

### Operating conditions

Transverse forces in Z direction	29000 N ... 800000 N	Maximum permissible force
Max. temperature	+100 °C	
Min. temperature	-45 °C	

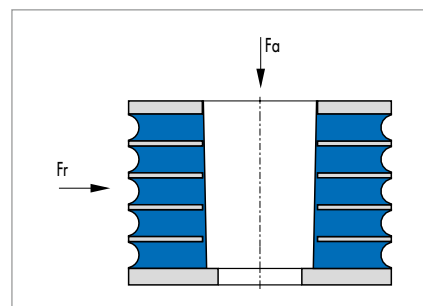

Fig. 2 Primary load directions

Layered springs have the same stiffness in the radial directions (X and Y direction) and are especially stiff in the vertical direction (Z direction). The effective stiffnesses can be varied by turning of the mount to the static load. Layered springs are designed for the primary load in the axial and radial direction but can also be loaded angled to the vertical primary load. The weight should be absorbed in the longitudinal axis for this.

### Design notes

The layered spring comprises at least two metal components arranged in parallel on top of one another which are firmly attached to elastomer inserts located between them through vulcanisation. Layered Springs are designed as bearings but they can also be arranged angled to the vertical primary load.

### Fitting & installation

- Individual components permit slight adjustment to allow for in-situ planar or angular offset
- Layered springs are generally installed in axial alignment with the primary load. Utilise the entire flat surface areas of the other metal parts as bearing surfaces and apply the load uniformly
- Install the mount so that the outer metal parts of the layered springs are preloaded relative to each other
- When installing angled to the vertical primary load, it is important to ensure sufficient lateral mould closing – full-surface attachment of the outer metal parts. Ensure that the outer metal parts are preloaded relative to each other.

**Article list**

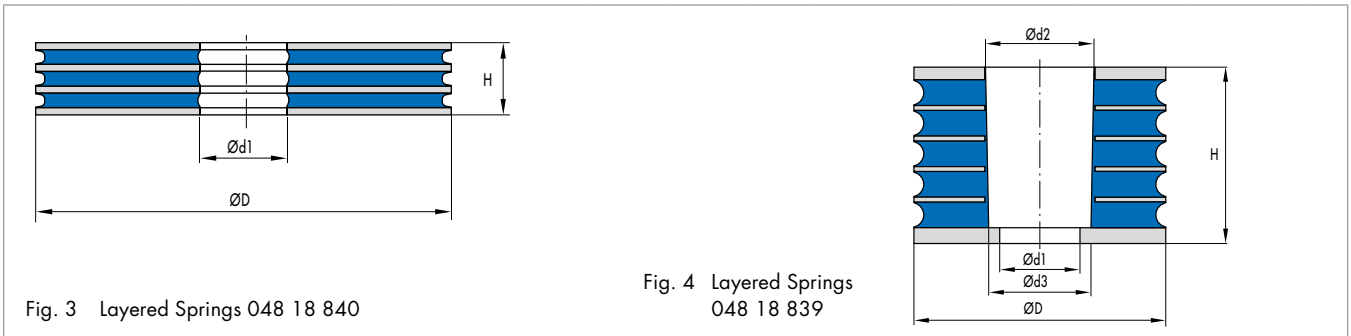

Fig. 3 Layered Springs 048 18 840

Fig. 4 Layered Springs 048 18 839

Nominal maxima			Stiffness			Outside Ø	Inside Ø			Height	Product No.	Material	Article No.	
Axial pressure			Radial shear				d1	d2	d3					
F <sub>a max</sub>	S <sub>a max</sub>	C <sub>a</sub>	F <sub>r max</sub>	S <sub>r max</sub>	C <sub>r</sub>	D	d1	d2	d3	H				
[N]	[mm]	[N/mm]	[N]	[mm]	[N/mm]	[mm]	[mm]	[mm]	[mm]	[mm]				
29000	9,0	3200	2500	10	250	160	51	69	65	112	048 18 839	60 CR 57	49033025	○
29000	9,0	3200	2500	10	250	160	51	69	65	112	048 18 839	60 NR 11	49033024	○
29000	9,0	3200	2500	10	250	160	51	69	65	112	048 18 839	60 NR 39	49033027	○
29000	9,0	3200	2500	10	250	160	51	69	65	112	048 18 839	60 NR 97	49033026	○
210000	2,5	84000	3800	5	760	230	48	-	-	40	048 18 840	40 NR 11	49041112	●
320000	2,5	128000	5900	5	1180	230	48	-	-	40	048 18 840	50 NR 11	49041113	●
500000	2,5	200000	9000	5	1800	230	48	-	-	40	048 18 840	60 NR 11	49041114	●
800000	2,5	320000	14000	5	2800	230	48	-	-	40	048 18 840	70 NR 11	49041115	●

● Available from stock    ○ On request: Tool is available, delivery at short notice

# Rubberised Stop Washer

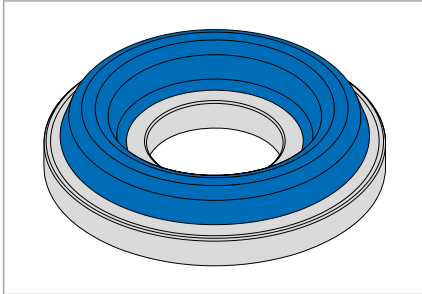

Fig. 1 Rubberised Stop Washer

## Product description

Stop Washers are versatile components for effectively limiting movements.

## Product advantages

- Robust
- Easily installed
- Optional
- RoHS-compliant.

## Application

Stop Washers effectively limit movements of loads with moving and unmoving units, machines and stops. They are preferably used for axial path limitation with Conical Mounts or Ultra Bushes.

## Material

Standard material	Hardness
Natural rubber	60, 70, 80 Shore A
Acrylonitrile-butadiene rubber NBR 68	70 Shore A

## Operating conditions

Diameter, outside in mm	40, 49, 65, 75, 90
Max. temperature	+60 °C, transient +80 °C
Min. temperature	-45 °C

Elastomer-coated stop washers have different stiffnesses and damping properties primarily in dependence on the rotation cross section, the height of the elastomer pad and the elastomer as well. They have the same stiffness in the radial directions (X and Y direction) and are considerably stiffer in the axial load direction. The trapezoid design of the elastomer pads (observed in the cross section) will achieve, for otherwise equal sizes, diameters and heights, a "softer" distribution of the characteristic curve as opposed to the rectangular design. The constricted body design produces smaller stiffnesses in the axial direction and, as a rule, leads to higher service life for otherwise equal deflection. The stiffness in the axial direction increases noticeably from variant I to III. The weight should be absorbed in the longitudinal axis.

## Design notes

The mount consists of a washer with or without central hole, with an elastomer pad vulcanised onto one side.

## Fitting & installation

- Position stop washers centred relative to and normal to the axial primary load, and ensure that load is transferred by a smooth and flat face opposite to and making full-surface contact with the elastomer pad
- Make sure that fasteners such as screws, etc., do not restrict the range of deflection of the stop faces.

Article list

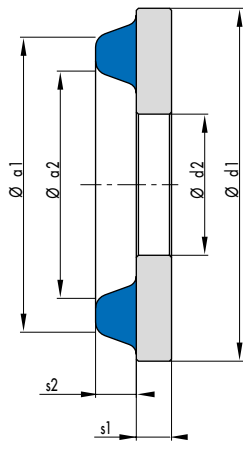

Fig. 2 Stop Washer Type I

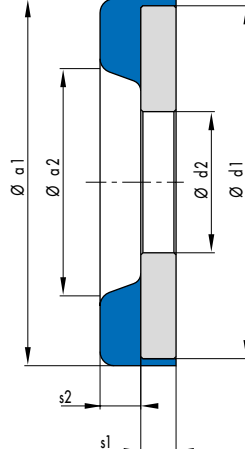

Fig. 3 Stop Washer Type II

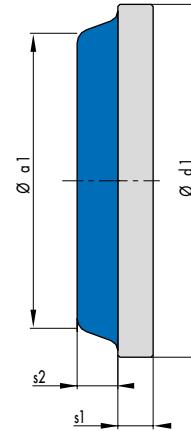

Fig. 4 Stop Washer Type III

Outside Ø metal		Hole Ø metal		Ø Rubber outside	Ø Rubber inside	Thickness		Type	Material metal	Material rubber	Product No.	Suitable to product	Article No.	
d1	Tol.	d2	Tol.	a1	a2	s1 metal	s2 rubber							
[mm]	[mm]	[mm]	[mm]	[mm]	[mm]	[mm]	[mm]		RM >= [N/mm <sup>2</sup> ]					
49	-1,3	12,5	0,2	44	28	3	3	I	ST 270	60 NR 11	039 18 005/101	057 18 226	93950	•
49	-1,3	12,5	0,2	44	28	3	3	I	ST 270	80 NR 11	039 18 005/101	057 18 226	93127	○
75	±1,0	16,2	0,3	65	47	4	5	I	ST 270	60 NR 11	077 18 700/101	057 18 013/ 057 18 756/ 057 18 757	511928	•
75	±1,0	20,2	0,2	65	47	6	5	I	ST 340	60 NR 11	040 18 048/101	057 18 013	90819	○
75	±1,0	20,2	0,2	65	47	4	5	I	ST 340	60 NR 11	077 18 007/102	057 18 013	90831	•
90	-0,25	24,1	0,3	78	60	8	8	I	ST 340	60 NR 11	077 18 003/102	057 18 019/ 057 18 019 HD	90501	•
75	±1,0	20,2	0,2	65	47	4	5	I	ST 340	70 NBR 68	077 18 007/102	057 18 013	511081	○
56	-0,4	21,0	±0,2	58	33	4	5	II	ST 270	70 NR 13	077 18 706/101	-	49042822	○
56	-0,4	16,0	0,5	58	33	4	5	II	ST 270	70 NR 13	077 18 710/101	-	49035471	•
75	-0,4	16,3	0,2	65	47	4	5	I	AL F28	70 NR 13	077 18 707/101	-	49042823	○
40	-0,4	-	-	33	-	2	3	III	ST 270	70 NR 13	077 18 705/101	-	60900266	○

## Washers and Centering Washers

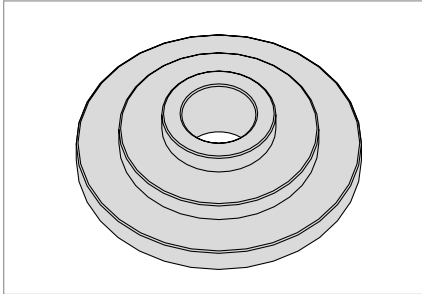

Fig. 1 Washers and Centering Washers

### Product description

Washers and centering washers are simple and cost-effective add-on elements and are available in different dimensions.

### Product advantages

- Robust
- Easily installed
- Optional
- RoHS-compliant.

### Application

Washers and centering washers are frequently used as stops for the elastomer bodies of selected conical mounts, MO mounts and ultra bushes.

### Material

Steel

min. 270 N ... 340 N

### Operating conditions

Diameter, outside in mm

35, 40, 48, 50, 60, 70, 75, 80, 100, 104, 110

The weight load should be applied along the longitudinal axis.

### Design notes

Washers and centering washers are additional components made of a cylindrical semifinished product. Each washer or centering washer has a central through-hole and a stepped shoulder on one face.

### Fitting & installation

- It is advisable to use DIN-compliant screws and other components for fitting and installation.



Article list

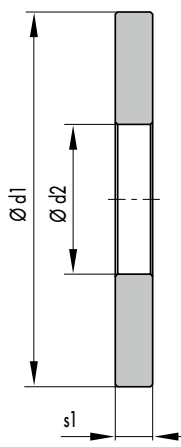

Fig. 2 Type I Washer

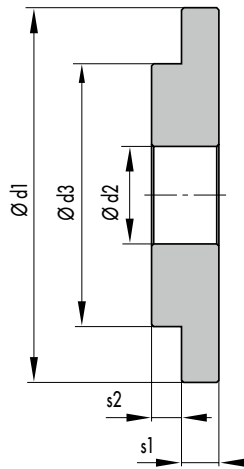

Fig. 3 Type II Centering Washer, single-tier

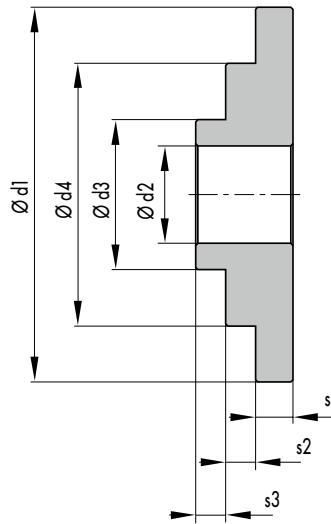

Fig. 4 Type III Centering Washer, two-tiered

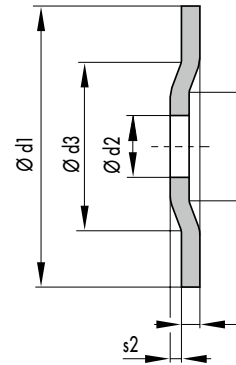

Fig. 5 Type IV Washer

Outside Ø		Bore Ø				Thickness			Product No.	Type	Material RM >= [N/mm <sup>2</sup> ]	Article No.	suitable with product	Corrosion protection			
d1	Tol.	d2	Tol.	d3	Tol.	d4	Tol.	s1								s2	s3
[mm]	[mm]	[mm]	[mm]	[mm]	[mm]	[mm]	[mm]	[mm]								[mm]	[mm]
40	±0,7	9,0	±0,5	-	-	-	-	2,5	-	-	039 18 753/212	I	270	49041777	3918753	Fe//Zn 8Znph/r/3	○
50	±0,7	11,0	±0,5	-	-	-	-	2,5	-	-	039 18 755/212	I	270	49041776	3918754/ 3918755/ 3918765	Fe//Zn 8Znph/r/3	○
70	±1	13,0	±0,5	-	-	-	-	3,0	-	-	039 18 768/212	I	270	49041778	3918768/ 3918769	Fe//Zn 8Znph/r/3	○
75	±1	16,2	0,3	-	-	-	-	4,0	-	-	040 18 922/101	I	270	49032678	-5718075/ 5718228	Fe//Zn12Znph/r/3	○
100	-1,5	23,8	±0,2	-	-	-	-	6,3	-	-	039 18 766/212	I	270	49041775	3918766	Fe//Zn 8Znph/r/3	○
35	±1,0	17,0	±0,2	28,0	-0,2	0	-	4,0	2	0	040 18 038/101	II	340	97139	5718060	Fe//Zn12Znph/r/3	●
48	±0,5	10,5	±0,2	15,0	r6	0	-	5,0	5	0	057 18 001/204	II	270	49056605	5718001 HD	Fe//Zn12Znph/r/3	○
60	±1,0	12,7	0,2	24,5	-0,2	0	-	5,0	3	0	040 18 039/101	II	340	97138	5718226	Fe//Zn12Znph/r/3	●
75	±1,0	20,2	0,25	35,0	-0,2	0	-	5,0	3	0	040 18 036/101	II	340	97141	5718013	Fe//Zn12Znph/r/3	●
104	±1,0	17,0	0,2	46,0	-0,2	0	-	5,0	3	0	040 18 037/101	II	340	97140	5718060	Fe//Zn12Znph/r/3	●
110	±1	24,1	0,2	45,9	-0,2	0	-	6	4	0	040 18 035/101	II	340	97142	5718019 5718019 HD	Fe//Zn12Znph/r/3	●
80	2	16,5	0,3	31,0	r6	43	-0,2	5	11	5	057 18 756/223	III	340	511927	5718756/ 5718757	Fe//Zn12Znph/r/3	●
75	±1	16,5	-0,3	45,0	±2,0	29	mind.	5	3	-	040 18 917/101	IV	270	49026836	5718075/ 5718228	Fe//Zn8//C	●

● Available from stock    ○ On request: Tool is available, delivery at short notice





**Freudenberg Schwab**  
Vibration Control

Freudenberg Schwab Vibration Control GmbH & Co. KG  
Dr.-Werner-Freyberg Str. 7  
D-69514 Laudenschbach  
Phone +49 6201 80 7002 | Fax +49 6201 88 7002

[info@freudenberg-schwab.com](mailto:info@freudenberg-schwab.com) | [www.freudenberg-schwab.com](http://www.freudenberg-schwab.com) | A company of the Freudenberg Group